



National
Defence

Défense
nationale

B-GL-372-004/FP-001

SKYGUARD DRILL BOOK

(ENGLISH)

(This publication becomes active on receipt.)

WARNING

ALTHOUGH NOT CLASSIFIED, THIS PUBLICATION, OR ANY PART OF IT, MAY BE EXEMPT FROM DISCLOSURE TO THE PUBLIC UNDER THE ACCESS TO INFORMATION ACT. ALL ELEMENTS OF INFORMATION CONTAINED HEREIN MUST BE CLOSELY SCRUTINIZED TO ASCERTAIN WHETHER OR NOT THE PUBLICATION OR ANY PART OF IT MAY BE RELEASED.

Issued on the authority of the Chief of the Land Staff

Canada



National
Defence

Défense
nationale

B-GL-372-004/FP-001

SKYGUARD DRILL BOOK

(ENGLISH)

(This publication becomes active on receipt.)

WARNING

ALTHOUGH NOT CLASSIFIED, THIS PUBLICATION, OR ANY PART OF IT, MAY BE EXEMPT FROM DISCLOSURE TO THE PUBLIC UNDER THE ACCESS TO INFORMATION ACT. ALL ELEMENTS OF INFORMATION CONTAINED HEREIN MUST BE CLOSELY SCRUTINIZED TO ASCERTAIN WHETHER OR NOT THE PUBLICATION OR ANY PART OF IT MAY BE RELEASED.

Issued on the authority of the Chief of the Land Staff

OPI: DAD 7

2000-11-30

Canada

FOREWORD

1. The *Skyguard Drill Book* is the operator's handbook. Thus, it does not contain a complete description of the Fire Control Unit (FCU). After completion of the operator's course, it is intended as a guide to be used by qualified operators in carrying out their duties.
2. Commands and reports are written in capital letters enclosed with quotation marks, e.g. "ATTENTION ALIGNMENT CHECK". Hardware lettering is written in capital letters, e.g. TROUBLE SUPPLY, CHANGE PRF, etc. This edition of the drill book is based on the following software:

a.	C2003 Main	CU 529 173 KVK
b.	C2003 Assistant	CU 529 171 KVK
c.	C2002 Interface	CU 529 240 KVK
3. For verification purposes, select menu 3/6—Actual Program Versions—from MK II MAIN MENU.

NOTE

Throughout Skyguard documentation, the term azimuth is used to define the horizontal deviation of a celestial or terrestrial point as referenced to a baseline such as the north direction or the longitudinal axis of the Skyguard. The synonymous expression bearing is most frequently used in navigation. Azimuth measurements (in mils) are always made clockwise from the reference direction.

4. A List of Abbreviations is included at the end of this manual. Operators may wish to review this List prior to proceeding.
5. Before attempting any tasks described in this manual operators must thoroughly review the safety and warning material contained in the following section.

PREFACE

SECTION 1 WARNINGS, SAFETY PRECAUTIONS AND FIRST AID

DANGER

1. **General Safety.** To avoid accidents during Skyguard Fire Control Unit (FCU) operation and maintenance, observe the following general safety rules:
 - a. **Do not** operate two FCUs at a distance closer than 40 metres.
 - b. **Do not** work alone on the FCU.
 - c. **Do not** move the FCU manually. Always use the direct towing vehicle. Secure a stationary FCU with the hand brake.
 - d. **Do not** tilt up the tracker if the FCU has not been coarsely levelled (weight taken off wheels).
 - e. **Do not** open the roof or tilt up the tracker if the wind speed is more than 120 kilometres per hour.
 - f. **Do not** enter the cabin when the tracker is tilting up, as long as TILT AXIS is not in OPERATION position.
 - g. **Do not** switch the main switch directly to OPERATION if the equipment is exposed to temperatures below -10°C. Preheat for 20 minutes in STAND-BY mode.
 - h. **Do not** use the main switch as a reset switch. The main switch **must** remain in the OFF position for at least 10 seconds.
 - i. **Do not** step onto the roof unless:

- (1) the MAN ON ROOF safety switch is switched to the MAN ON ROOF position and locked,
 - (2) the pushbuttons RADAR SILENCE X and RADAR SILENCE Ka have been depressed (lamp on),
 - (3) the laser service switch is switched to position LASER OFF, and
 - (4) the tracker drive service switches are switched to position ELEVATION DRIVE OFF, AZIMUTH DRIVE OFF and SA DRIVE OFF.
- j. **Do not** step on opened or non-slide-protected areas on the roof. Observe the safety labels.
- k. **Do not, when the weapons are loaded,** operate the FCU in conjunction with Training Simulator 1 (TS1) or Training Simulator 2 (TS2), **or** perform the Functional Check (FLC).
- l. **Do not** connect or disconnect the FCU power cable under voltage.
- m. **Do not** release the securing levers of the Power Supply Unit (PSU) when the FCU is in a sloping position.
- n. **Do not** operate the PSU in the service position except for maintenance purposes.
- o. **Do not** work outside the FCU in thunderstorms. Stay inside the FCU or evacuate.
- p. **Do not** approach within 15 metres of an operating FCU unless wearing ear protectors.

- q. **Do not** set up the Optical Sight (OS) closer than 15 metres to an operating FCU unless wearing ear protectors.

2. The following safety distances must be observed at 100% power:

RADAR AND LASER SAFETY DISTANCES					
	X-Band Search Radar Rotating Antenna	Stationary Antenna	X-Band Tracking Antenna	Ka-Band Tracking Antenna	Laser
Personnel	3 m	36 m	90 m	40 m	3500 m
Fuel Vapour	6 m	6 m	15 m	Safe	Safe

3. **Do not** open compartments before switching off the power supply. The electrical components operate with high voltage.
4. In the case of electrical accidents proceed as follows:
- switch off PSU before touching the victim;
 - remove the victim from the danger zone;
 - immediately call for medical help; and
 - start artificial respiration immediately and continue until medical help arrives.

RADAR SAFETY

5. **Do not** radiate energy when operating in closed quarters (switch on RADAR SILENCE or RECEIVE ONLY).

6. **Do not** direct the antennae of the FCU towards the antennae of other radar systems.
7. **Do not** direct the antennae of the FCU towards personnel.

LASER SAFETY

8. The laser rangefinder operates with an invisible beam that is dangerous to the eyes.
9. The laser safety range applies to the naked eye only. When binoculars or a telescope are used, the safety range must be increased by the magnifying factor of the optics.
10. **Do not** direct the laser towards people, animals and passing objects (cars, aircraft, etc.).
11. **Do not** operate the laser without the laser warning light (switch off the warning light only in combat).
12. **Do not** remain within the safety distance without safety glasses when the laser is operating without the attenuator.
13. **Do not** operate the laser without having the laser safety key switch connected to the FCU during operation or maintenance. An authorised safety representative, who fully controls laser enabling or disabling, must man the laser safety key switch. In wartime, the laser safety switch can be replaced by the laser safety override.

SECTION 2
BE PREPARED FOR THE EMERGENCY HOW TOS!

MOUTH TO MOUTH ARTIFICIAL RESPIRATION

14. **Drowning:**
 - a. remove from water;
 - b. loosen clothing;
 - c. place patient face upwards—clear mouth air passage if necessary;
 - d. apply artificial respiration;
 - e. send for a doctor; and
 - f. keep warm (with blankets, etc.).

15. **Gassing:**
 - a. remove to fresh air;
 - b. loosen clothing;
 - c. place patient face upwards—clear mouth air passage if necessary;
 - d. apply artificial respiration;
 - e. send for a doctor; and
 - f. keep warm (with blankets, etc.).

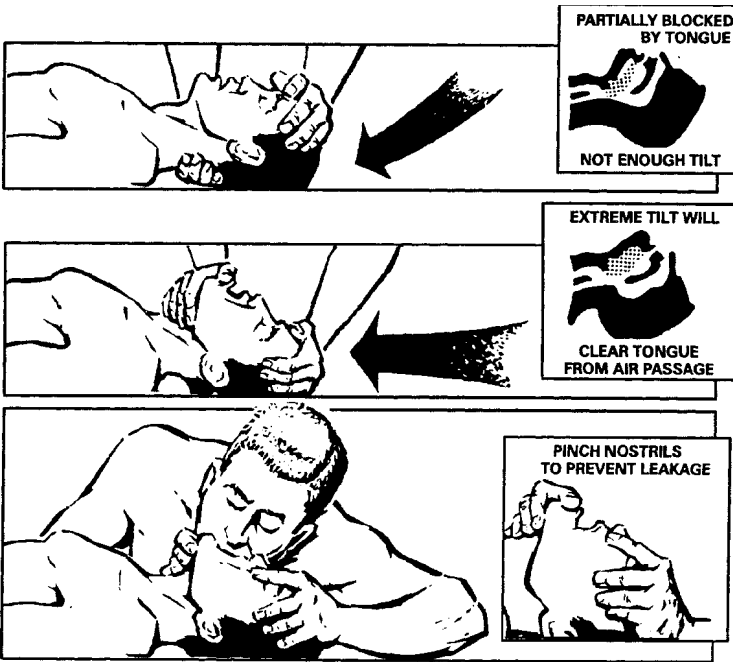

PLACE MOUTH TIGHTLY OVER SUBJECT'S MOUTH ... BLOW IN

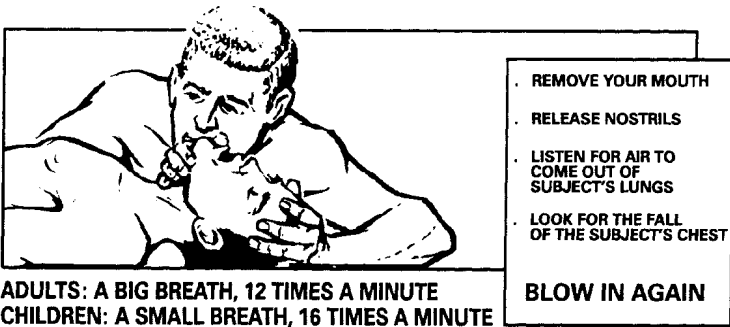

Figure 1: Mouth to Mouth Artificial Respiration

16. Electric Shock:

- a. protect yourself with dry insulating material (dry leather, wood, rubber, etc.);
- b. break the circuit by opening the power switch or by pulling the victim free of the line conductor;

- c. do not touch the victim with bare hands until the circuit is broken;
- d. place patient face upwards – clear mouth air passage if necessary;
- e. start artificial respiration quickly;
- f. send for a doctor; and
- g. keep patient warm with blankets, etc.

NOTE

1. Air passages must be kept open at all times.
2. If air passages are not open there will be:
 - a. no sound of escaping air;
 - b. no rise or fall of the chest; and
 - c. resistance when blowing into the subject's mouth.
3. Therefore:
 - a. check neck and head; and
 - b. check mouth and throat for foreign substances.

**SECTION 3
HOLGER-NIELSEN METHOD OF ARTIFICIAL
RESPIRATION**

ALTERNATIVE METHOD

17. If breathing stops because of electrocution, drowning, sedative poisoning, gas poisoning, suffocation, or poliomyelitis, start

artificial respiration immediately. Do not delay—seconds count. Send someone for a physician as soon as possible.

18. The standard technique for the back pressure/arm lift method is as follows:

- a. place the patient face down, elbows bent, one hand on the other with the face turned to one side;



Figure 2a: First Step to the Holger-Nielsen Method of Artificial Respiration

- b. place your hands, thumbs touching, just below a line running between the armpits;



Figure 2b: Second Step to the Holger-Nielsen Method of Artificial Respiration

- c. rock forward slowly, elbows straight, until arms are vertical;



Figure 2c: Third Step to the Holger-Nielsen Method of Artificial Respiration

- d. rock backward, sliding your hands to the patient's arms, just above the elbows;



Figure 2d: Fourth Step to the Holger-Nielsen Method of Artificial Respiration

- e. raise the arms until resistance and tension are felt at the patient's shoulders; and

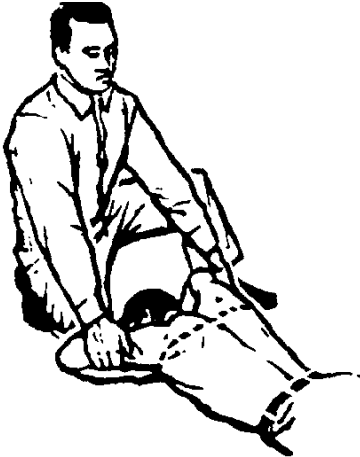

Figure 2e: Fifth Step to the Holger-Nielsen Method of Artificial Respiration

- f. repeat the cycle 12 times per minute.

TABLE OF CONTENTS

FOREWORD i
PREFACE	
SECTION 1 WARNINGS, SAFETY PRECAUTIONS AND FIRST AID iii
Danger iii
Radar Safety v
Laser Safety vi
SECTION 2 BE PREPARED FOR THE EMERGENCY HOW TOS! vii
Mouth to Mouth Artificial Respiration vii
SECTION 3 HOLGER-NIELSEN METHOD OF ARTIFICIAL RESPIRATION x
Alternative Method ix
CHAPTER 1 GENERAL	
Transport and Operation Information 1
Layout of a Skyguard Section 4
FCU Detachment Duties 4
CHAPTER 2 DEPLOYMENT	
Preparations 9
Issuing Commands 10
Deployment Drill 11
Halt—Prepare for Action Drill 12
Starting the PSU 14
Halt—Prepare for Action—PSU Start Up 15
CHAPTER 3 FIRE CONTROL UNIT (FCU)— COMING INTO ACTION 17
Halt—Action, Action, Action 18
Operational Readiness Check 23

Enter Date and Time..... 24

Data for X-Band Search Radar 25

Data for X-Band Tracking Radar 28

Data for KA-Band Tracking Radar..... 29

Data for Electro-Optical Group 30

Data for Laser 31

Data for Identification Friend or Foe (IFF) 35

North Orientation 37

Definition of Reference Points with EOG 40

Inspection of Reference Points 41

OS Orientation..... 42

OS Alignment Check..... 44

Preparation of Skyguard for Training Simulator 2 (TS 2)..... 44

**CHAPTER 4 SKYGUARD SECTION—
COMING INTO ACTION**

Communication, Power Supply Unit (PSU) Run Up
and Data Transmission Check 47

Enter Weapon Data..... 49

Weapon Orientation..... 50

Direct Orientation..... 51

Indirect Orientation 53

Alignment Check..... 57

Zero Test 58

Fictitious Target Firing with Guns 59

Meteorological Data 61

Lower Limit for Acquisition..... 62

Position of Own FCU 63

Priority Sector Limits 63

Position of Vital Point 65

Position of Neighbouring FCUs and Surveillance Radar	65
Battery Command Post (BCP).....	66
Technical Skyguard Section Configuration.....	67
Tactical Skyguard Section Configuration.....	67

CHAPTER 5 OPERATION MODES

Rain Clutter Suppression	69
Ground Clutter.....	69
Designation Radar	70
Designation Mode 1.....	71
Designation Mode 2.....	73
Designation Mode 3.....	74
Designation Mode 4.....	76
Designation Optical Sight (OS)	77
Broadband and Spot Noise Jammer.....	78
Blinking Noise Jammer	79
Interference.....	80
Range Gate Stealer	81
Chaff.....	82
False Target Deceptions	82
Tracking Modes.....	83
Tracking Memory.....	85
Passive Tracking.....	86
Firing	86
Air-to-Surface Missile (ASM) Alarm.....	87
Target Change within Formation via Range Trace.....	88
Target Change within Formation via TV Monitor.....	89
Local Take-over and Remote Acquisition of Non-autonomous Gun.....	90

Local Take-over With Autonomous Gun 91

CHAPTER 6 COMING OUT OF ACTION

Prepare to Move 93

Cease Firing..... 93

CHAPTER 7 RANGE FIRING 101

SECTION 1 SYSTEMATIC SEQUENCE FOR SKYGUARD
SECTION COMING INTO ACTION 102

SECTION 2 DUTIES OF THE SKYGUARD SECTION
COMMANDER 103

Before Firing 103

During Firing..... 103

SECTION 3 DUTIES OF WEAPON SAFETY OFFICER/
LASER SAFETY SUPERVISOR..... 104

Before Firing 104

During Firing..... 105

After Firing..... 105

SECTION 4 RANGE SUPPORT EQUIPMENT 105

FCSS..... 106

CIS..... 106

VES 107

Settings for VES 107

SECTION 5 SAFETY SECTORS 107

Laser Sector 108

Fire Sector 108

Set Laser Sector..... 108

Set Fire Sector 109

Check Laser Sector..... 110

Check Fire Sector 112

SECTION 6 SKYGUARD LASER/SAFETY CHECK..... 114

SECTION 7	GUN LASER/SAFETY CHECK	117
SECTION 8	FIRE TRIGGER/SAFETY CHECK	120
SECTION 9	FIRING AT TOWED TARGETS	124
CHAPTER 8	DETERMINE BALLISTIC DATA AND RANGES.....	127
	Atmospheric Pressure	128
	Air Temperature	128
	Humidity	128
	Wind Speed and Direction.....	128
	Initial MV Calculation.....	130
	Range Determination to Reference Point by Means of Radar.....	134
	Range Determination to Reference Point by Means of Laser	135
CHAPTER 9	OPERATION WITH DEGRADED EQUIPMENT	
	Start the PSU with External Battery	137
	Start the PSU in Case of Emergency	137
	Operate the Hydraulic Group Manually	138
	Extend/Retract Hydraulic Jacks and Coarse Levelling.....	138
	Open/Close the Roof	139
	Tilt Up/Down the Tracker	139
	Manual Fine Levelling.....	140
	Weapon Orientation with Reference Optics	140
	Orientation of Optical Sight (OS) with Reference Optics ...	142
CHAPTER 10	MAINTENANCE AND CARE	
SECTION 1	SPECIAL SAFETY PRECAUTIONS	143
SECTION 2	SUPPLIES AND LUBRICANTS	143
	Fuel	143

- Engine Oil..... 144
- SECTION 3 OPERATIONAL SUPPLIES
AND MATERIALS 146
 - Fuels and Lubricants..... 146
 - Application of Fuels and Lubricants..... 146
- SECTION 4 MISCELLANEOUS SUPPLIES AND
MATERIALS 147
- SECTION 5 SPECIAL TOOLS AND TEST EQUIPMENT.. 147
- SECTION 6 PREVENTIVE MAINTENANCE TASKS..... 148
 - Check Hydraulic Fluid Level 148
 - Check Engine Oil Level (See Figure 10-3) 149
 - Empty Dust Collector Reservoir on Air Filter
(See Figure 10-4)..... 149
 - Drain Fuel Filter and Water Separator
(See Figure 10-5)..... 151
 - Clean and Lubricate Battery Terminals 151
 - Check Coolant Level (See Figure 10-6) 152
 - Check Battery Electrolyte Level and
Refill if Necessary 152
 - Check Radiator 154
- SECTION 7 FAULTFINDING/TROUBLESHOOTING 154
 - Lamp TROUBLE SUPPLY 155
 - Lamp TROUBLE SUPPLY is Blinking 155
 - Lamp TROUBLE SUPPLY is On 156
 - Lamp WARNING is On 156
 - Lamp SAFETY is On 157
 - Lamp TROUBLE VENTILATION is On 158
 - Lamp SUBSYSTEM OFF is On 158
 - Lamp TROUBLE COMPUTER is On 159
 - Lamp TROUBLE SUBSYSTEM..... 159

Lamp TROUBLE SUBSYSTEM is Blinking.....	159
Lamp TROUBLE SUBSYSTEM is On.....	161
Lamp TROUBLE SUBSYSTEM is On During Normal Operation	161
Lamp TROUBLE SUBSYSTEM is On During BIT	162
Lamp TROUBLE at the PSU is On.....	162
Lamp PUMP ON Remains Off After Hydraulic Pump is Started	163
Lamp SAFETY ROOF is Off	163
SECTION 8 CORRECTIVE MAINTENANCE.....	164
Instructions for Repair Work	165
Adjustments	165
Remove/Replace Lamps at the Operator Console (See Figure 10-7)	165
Remove/Replace Vehicle Lighting Lamp.....	165
Remove/Replace Batteries on the PSU (See Figure 10-8)	166
Top Up Battery Electrolyte Level.....	167
Remove/Replace Lamps on the Switch-On Panel (See Figure 10-9)	168
Remove/Replace Cabin Lighting Lamps	168
Remove/Replace Wheel (See Figure 10-10).....	169
LIST OF ABBREVIATIONS.....	171

LIST OF FIGURES

Figure 1: Mouth to Mouth Artificial Respiration viii

Figure 2a: First Step to the Holger-Nielsen Method of Artificial
Respiration x

Figure 2b: Second Step to the Holger-Nielsen Method of Artificial
Respiration xi

Figure 2c: Third Step to the Holger-Nielsen Method of Artificial
Respiration xi

Figure 2d: Fourth Step to the Holger-Nielsen Method of Artificial
Respiration xii

Figure 2e: Fifth Step to the Holger-Nielsen Method of Artificial
Respiration xii

Figure 1-1: Transport Position 1

Figure 1-2: Height, Width and Ground Clearance 2

Figure 1-3: Turning Radius 2

Figure 1-4: Maximum Side Slope 3

Figure 1-5: Transportation by Rail 3

Figure 1-6: Operating Position 4

Figure 1-7: Layout of a Skyguard Section 4

Figure 3-1: Definitions of Terms in North Orientation
With Reference Point 37

Figure 3-2: Definitions of Terms in North Orientation with
Aiming Circle 39

Figure 4-1: Definitions of Terms Used in Direct Orientation 51

Figure 4-2: Definitions of Terms Used in Indirect Orientation 53

Figure 7-1: Systematic Sequence for Skyguard Section
Coming Into Action 102

Figure 8-1: MV According to Barrel Stress MV_{bs} for HEI and TP
Ammunition 132

Figure 8-2: MV Deviation According to Powder Temperature
 ΔMV_{pt} (AHEAD, HEI and TP) 133

Figure 10-1: Engine Oil Viscosities 145

Figure 10-2: Cap Extractor 148

Figure 10-3: Engine Oil Cap and Dipstick..... 150

Figure 10-4: Dust Collector Reservoir 151

Figure 10-5: Fuel Filter and Water Separator 153

Figure 10-6: Coolant Receptacle and Level Mark 154

Figure 10-7: Remove/Replace Lamps at the Operator Console 166

Figure 10-8: Remove/Replace Batteries 167

Figure 10-9: Remove/Replace Lamps on the Switch-On Panel 169

Figure 10-10: Remove/Replace Wheel 170

CHAPTER 1 GENERAL

1. This part contains information regarding transport and operation of the Fire Control Unit (FCU), the layout of a Skyguard Section, and the duties of FCU personnel.

TRANSPORT AND OPERATION INFORMATION

2. Figures 1-1 to 1-6 depict FCU dimensions for different transport and operating configurations. In addition, note the following:

- a. Fordability—600 mm.
- b. Maximum Towing Speed :
 - (1) Highway—80 km/h;
 - (2) cross-country—15 km/h; and
 - (3) weight with Power Supply Unit (PSU)—6800 kg.

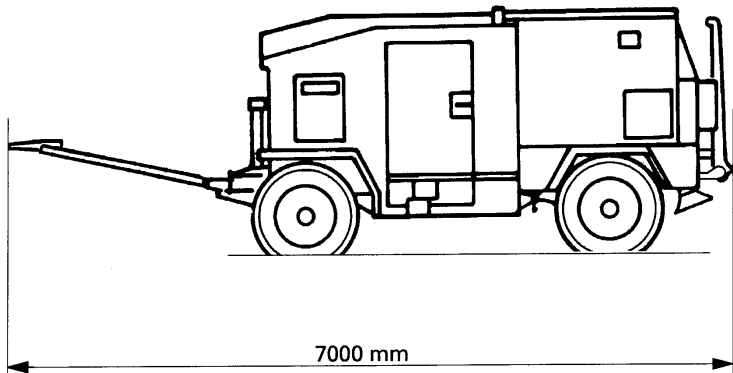

Figure 1-1: Transport Position

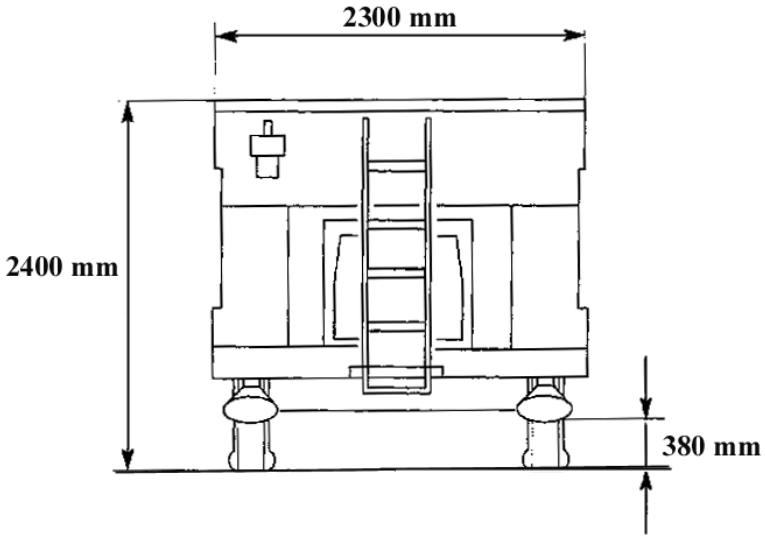

Figure 1-2: Height, Width and Ground Clearance

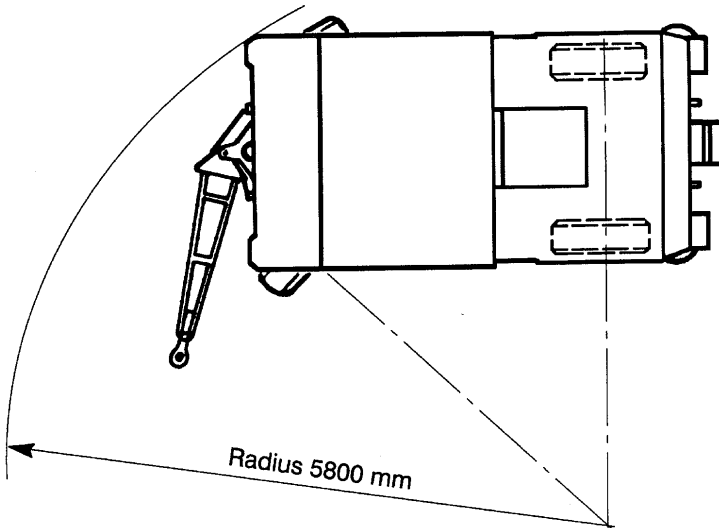

Figure 1-3: Turning Radius

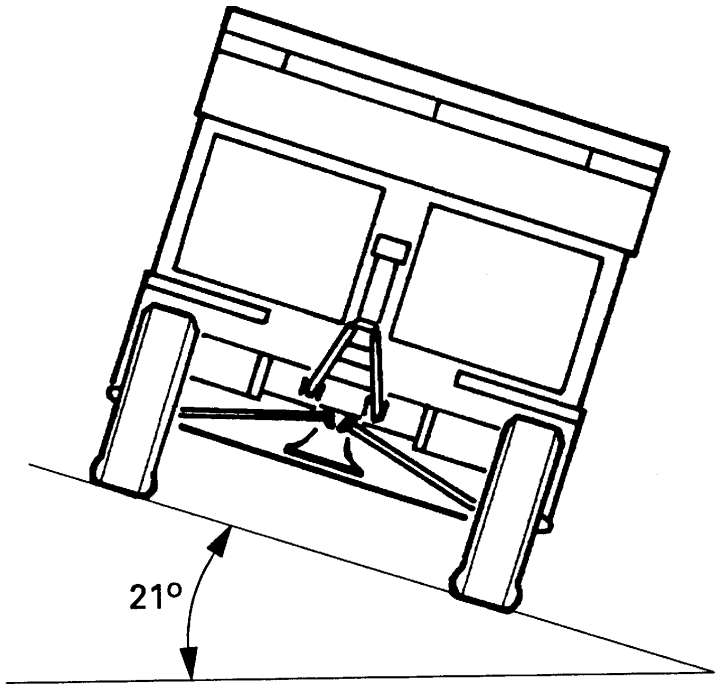
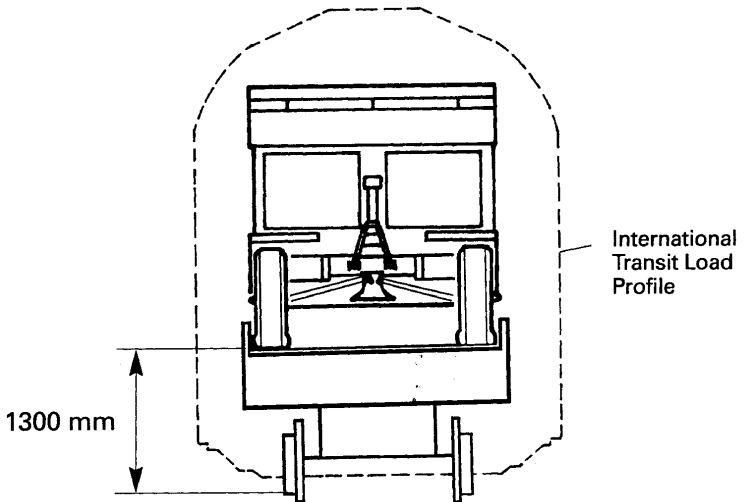

Figure 1-4: Maximum Side Slope

Figure 1-5: Transportation by Rail



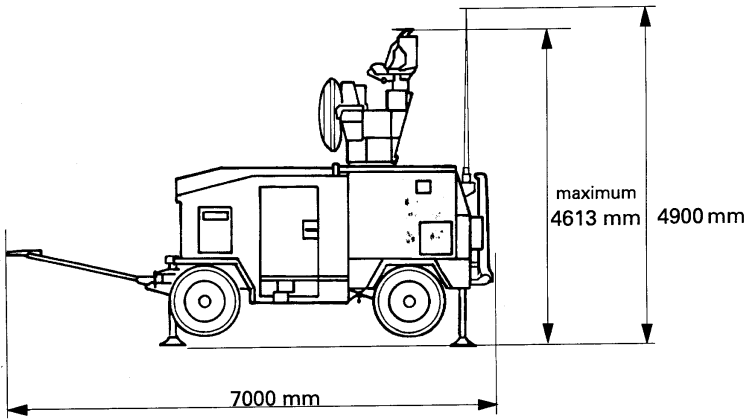

Figure 1-6: Operating Position

LAYOUT OF A SKYGUARD SECTION

3. The maximum distances associated with Skyguard Section deployment are shown in Figure 1-7. Gun detachments are also depicted.

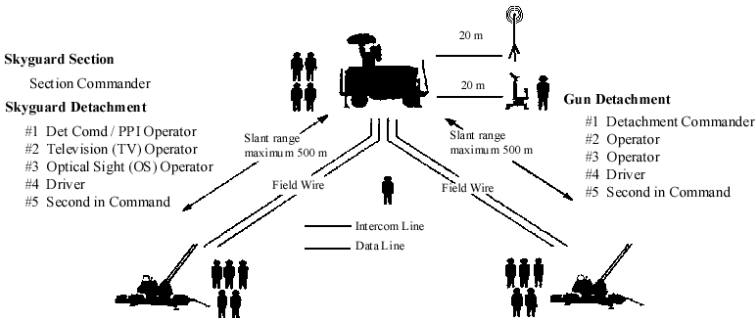

Figure 1-7: Layout of a Skyguard Section

FCU DETACHMENT DUTIES

4. The duties of FCU detachment members are as follows:

- a. **Section Commander:**
 - (1) Commands the Skyguard Section.

- (2) General supervision and direction of the FCU.
- (3) Passage of technical and tactical information to the battery command post (BCP).
- (4) Administrative duties as directed by the Gun Troop Commander (TC).
- (5) Plans and implements local defence of the Skyguard Section.
- (6) Relieves the Gun Troop Sergeant Major (TSM) or the Skyguard Detachment Commander as required.
- (7) Commands data link selection to/from BCP.

b. **Skyguard Detachment Commander/Plan Position Indicator (PPI) Operator:**

- (1) Prepares FCU and Skyguard Section for operation.
- (2) Performs limited maintenance tasks.
- (3) Camouflages the FCU.
- (4) Prepares FCU for transport.
- (5) Implements local defence plan under direction of the Section Commander.
- (6) Acts as PPI Operator during Skyguard Section operation.
- (7) Relieves the Section Commander as required.

c. **TV Operator:**

Skyguard Drill Book

- (1) Assists in preparing FCU and Skyguard Section for operation and transport.
- (2) Assists OS Operator in preparation of the OS.
- (3) Performs limited maintenance tasks.
- (4) Camouflages the FCU.
- (5) Acts as TV Operator during Skyguard Section operation.
- (6) Assists OS Operator in setting up UHF antenna.

d. **OS Operator:**

- (1) Prepares the OS for operation.
- (2) Assists in preparing the FCU for operation.
- (3) Camouflages the FCU and the OS.
- (4) Ensures the PSU has adequate fuel.
- (5) Performs limited maintenance tasks.
- (6) Acts as OS Operator during Skyguard Section operation.
- (7) Relieves TV Operator as required.
- (8) Prepares OS for transport.
- (9) Prepares and sets up UHF antenna.

e. **Driver:**

- (1) Drives the towing vehicle.

- (2) Loads and unloads stores from towing vehicle.
- (3) Camouflages towing vehicle.
- (4) Maintains towing vehicle.
- (5) Assists in FCU maintenance as required.
- (6) Relieves TV and OS Operator as required.

f. **Second in Command:**

- (1) Organizes local defence of the Skyguard Detachment.
- (2) Relieves the Detachment Commander (PPI Operator) as required.

CHAPTER 2 DEPLOYMENT

1. Skyguard deployment subsequent to conducting a reconnaissance and establishing a defensive perimeter for a group of several Skyguard Sections is described in this part.

PREPARATIONS

SECTION COMMANDER	FIRE CONTROL UNIT (FCU) AND WEAPON DETACHMENT
<p>Receives the mission order containing information on the following:</p> <p>General Situation. Data on enemy and allied troops.</p> <p>Mission</p> <ul style="list-style-type: none"> • site to be protected; • tactical defence formation; • position of each FCU; and • start time for operational readiness at the Skyguard Section site. <p>Special Data</p> <ul style="list-style-type: none"> • access roads to be used by each Skyguard Section; • start time of move to assembly area; • communication with the tactical command post; • supply of material and ammunition; • logistics; and 	<p>Checks equipment and stores for completeness and functional readiness.</p> <p>Loads equipment and stores on available vehicles.</p>

SECTION COMMANDER	FIRE CONTROL UNIT (FCU) AND WEAPON DETACHMENT
<ul style="list-style-type: none"> • position of tactical command post. <p>Prepares the orientation briefing for the Skyguard Section detachment.</p>	

ISSUING COMMANDS

SECTION COMMANDER, FCU AND WEAPON DETACHMENT
<p>Section Commander briefs all personnel on:</p> <ul style="list-style-type: none"> • general situation; • mission; • site for Skyguard Section deployment; • special conditions and arrangements; and • start time for operational readiness at the Skyguard Section site. <p>Section Commander briefs Section 2IC, the Detachment Commander and driver on:</p> <ul style="list-style-type: none"> • route to the assembly area; • activities at the assembly area; • the order in which equipment is to be deployed; • route between the assembly area and the Skyguard Section site; • locations of individual deployments, supply depots and ammunition dumps;

**SECTION COMMANDER, FCU AND WEAPON
DETACHMENT**

- personnel organization; and
- vehicle formation during movement.

DEPLOYMENT DRILL

GUN 1	FCU	GUN 2
<p>Deploys the gun.</p> <p>Establishes readiness to fire.</p> <p>Loads the gun.</p> <p>Assures anti-aircraft defence during the deployment of FCU and Gun 2.</p> <p>Establishes communications with FCU via field telephone lines.</p> <p>Alignment of Skyguard Section.</p>	<p>Deployment of FCU.</p> <p>Establishes operational readiness.</p> <p>Obtains weather data.</p>	<p>Deploys the gun.</p> <p>Establishes readiness to fire.</p> <p>Establishes communications with FCU via field telephone lines.</p> <p>Loads gun.</p>

GUN 1	FCU	GUN 2
<p>Establishes supply and ammunition depots.</p> <p>Camouflage.</p> <p>Builds field-type protective fortification.</p>	<p>Measures muzzle velocity.</p>	

HALT—PREPARE FOR ACTION DRILL

NO 1 (NO 5)	NO 2	NO 3
<p>"HALT, PREPARE FOR ACTION"</p> <p>Ensure FCU operation switch is OFF.</p> <p>Install radio antenna.</p>	<p>Dismount.</p> <p>Roll up Power Supply Unit (PSU) tarpaulin.</p>	<p>Dismount.</p> <p>Roll up PSU tarpaulin.</p>
<p>NOTE</p> <p>(At this time No 1 goes to Orders and No 5 takes over)</p>	<p>Verify that F2 and F3 are depressed.</p>	<p>Verify that F1 is depressed (located on the suppresser housing on the FCU).</p>
	<p>Pull out PSU.</p>	<p>Pull out PSU.</p>

NO 1 (NO 5)	NO 2	NO 3
	<p>Check coolant.</p> <p>Check electrolyte level.</p> <p>Check cable on distribution box.</p> <p>Push in and lock PSU.</p> <p>Roll side tarpaulins.</p> <p>Report faults to No 1 or No 5.</p>	<p>Check cable connection PSU/FCU.</p> <p>Check engine oil level.</p> <p>Check coolant hoses.</p> <p>Check PSU environment for oil/water leakage.</p> <p>Push in and lock PSU.</p> <p>Roll side tarpaulins.</p> <p>Report faults to No 1 or No 5.</p>

STARTING THE PSU

DANGER

1. Comply with the following safety rules when operating the PSU:
 - a. Prevent exhaust gases from being blown in the direction of the FCU.
 - b. During operation, the exhaust tube can reach high temperatures. Fire risk due to dry grass, straw, supplies, etc., in the area around the end of the tube must be taken into account.
 - c. If the FCU site is below ground level, exhaust gas should in no case enter this area (danger of asphyxiation).
 - d. If the camouflage net has been hung over the FCU, the end of the exhaust tube must be outside of the net (danger of asphyxiation and/or fire).

WARNING

Put on protective gloves before touching the exhaust tube, during or after concluding operations, in order to avoid burns. Never connect or disconnect the PSU/FCU cable while the PSU is running.

NOTE

1. Under extreme climatic conditions (temperature below -30°C), the PSU may start only when an external battery is connected (refer to Section 9.1).
2. If the PSU has to withstand extreme cold, verify that the engine oil corresponds to the requirements of Figure 10-3 and the fuel to those of Figure 10-1.

HALT—PREPARE FOR ACTION—PSU START UP

NO 2	DISPLAY
Set BATTERY switch to I	O or F
Activate switch DISPL TEST and check display.	8888 1111 - 0000
Set operation switch to STANDBY.	A B
Wait until B appears on display.	C1
Actuate toggle switch START.	C2 D
<p style="text-align: center;">NOTE</p> <p>Filter flaps will not be opened at this location unless STANDBY pre-heat procedures are carried out. The GENERATOR will not be switched to ON unless the PSU is at the maximum of 4000 RPM.</p>	

CHAPTER 3
FIRE CONTROL UNIT (FCU)—COMING INTO ACTION

1. The sections in this part are arranged in the sequence which must be followed in order to complete all tasks necessary for correct preparation of the FCU.
2. The numerical keyboard and the cursor keyboard are used to enter numerical values into the computer and to position the cursor on the display. Keyboard pushbutton functions are as follows:

KEY(S)	FUNCTION
0-9	Entry of numerical values. The values entered appear on the Plasma Display Monitor (PDM).
-	Polarity sign.
•	Decimal point.
CL	The last character entered is cleared.
ENTER	The computer reads the entered value.
→ ← ↓ ↑	The cursor moves in the corresponding direction. Defined cursor position.
CLP	All values on the corresponding page are cleared.
DV	The default value is inserted at the corresponding position.
MENU	Calls up the main menu.
EXIT	Return to the next higher menu level.
UP	Stepping up through defined parameters.
DOWN	Stepping down through defined parameters.
YES/NO	Confirming and answering questions in response to PDM prompts.

KEY(S)	FUNCTION
DP	The default values are inserted on the corresponding page.
HELP	Supplementary explanations are faded in.

HALT—ACTION, ACTION, ACTION

NO 1	NO 2	NO 3	NO 4	NO 5
<p>Guide vehicle to gun marker (the flag of the gun marker is facing the centre of arc).</p> <p>"HALT, ACTION, ACTION, ACTION".</p> <p>Apply hand brake.</p> <p>Insert wheel chock.</p> <p>"DRIVE ON — HALT" (approximately 5 m).</p>	<p>Dismount.</p> <p>Disconnect yellow brake hose and lighting cable.</p> <p>Assist unhooking towbar.</p>	<p>Dismount.</p> <p>Disconnect red brake hose.</p> <p>Assist unhooking towbar.</p>	<p>Drive on—halt.</p>	<p>Dismount.</p>

Fire Control Unit (FCU)—Coming Into Action

NO 1	NO 2	NO 3	NO 4	NO 5
	<p>Open filter flaps.</p> <p>Place fire extinguisher next to Power Supply Unit (PSU).</p>	<p>Install refuelling device and activate FUEL switch.</p>	<p>Unload stores.</p>	<p>Unload stores.</p>

NO 1	NO 2	NO 3
<p>Direct Optical Sight (OS) and Aiming Circle position.</p> <p>Open flap to hydraulic pump equipment.</p> <p>Set flow control lever to COARSE.</p> <p>Press PUMP ON.</p>	<p>Set operation switch to OPERATION.</p> <p>Bring OS to directed position.</p> <p>Assist in setting up OS.</p> <p>Roll out OS cable.</p> <p>Connect cable to FCU at the OS connector panel.</p> <p>Connect the laser safety switch (if required).</p>	<p>Connect exhaust tube.</p> <p>Bring OS to directed position.</p> <p>Set up OS.</p> <p>Assist rolling out OS cable.</p> <p>Connect cable to OS</p> <p>Sit on and level OS.</p>

NO 1	NO 2	NO 3
<p>Raise FCU until wheels are off ground.</p> <p>Unlock hand levers.</p> <p>Level FCU using bubble.</p> <p>Set flow control lever to FINE.</p> <p>Close the flap.</p>		<p>Connect field wires for weapons.</p> <p>Connect field wires for external station.</p> <p>Set up Aiming Circle at directed position (approximately 200 m).</p>

CAUTION

Check to see if swivel space for roof and tracker is free of obstacles. Clean roof of snow and ice.

NO 1	NO 2
<p>"OPEN ROOF"</p> <p>Open door and release roof lock (right).</p> <p>Check cleanliness of camera optics.</p> <p>Ensure towbar is down.</p>	<p>Open door and release roof lock (left).</p> <p>Check cleanliness of laser optics.</p>

NO 1	NO 2
<p>Check if SAFETY ROOF and PUMP ON lamps are ON.</p> <p>Press OPEN ROOF until roof is completely open.</p> <p>Press TRACKER TILT UP until tracker is completely tilted up.</p> <p>Set handle TILT AXIS to OPERATION.</p> <p>Set handle ELEVATION to OPERATION.</p> <p>Set handle SEARCH ANTENNA to OPERATION.</p> <p>Press CLOSE ROOF until roof is completely closed.</p> <p>Press PUMP OFF.</p>	
<p>Lock roof (right).</p>	<p>Lock roof (left).</p>
<p>Put bench into working position.</p>	<p>Put bench into working position.</p>
<p>Roll up operator console cover.</p>	<p>Set handle AZIMUTH to OPERATION.</p>
<p>Swing down hinged table.</p>	<p>Install tarpaulin behind bench (if necessary).</p>

3. The elapsed time from switching on the FCU until the radar is ready for operation is approximately five minutes.

4. If the temperature is -10°C or lower, set the main switch to STANDBY and preheat for 20 minutes. Preheating is also possible during transport.

5. The default values and key functions are presented in the help menu for each step.

6. Lamps with two filaments are installed throughout the Skyguard system. When performing the lamp test, verify that all lamps glow at the same intensity. If one or both filaments have failed, the lamp must be replaced.

WARNING

1. To avoid accidents while performing further steps in this procedure, always ensure the following after switching on:

- a. Lamp LASER DISABLE on.
- b. Lamp RADAR SILENCE X on.
- c. Lamp RADAR SILENCE KA on.
- d. Lamp AUTO FIRE TO MISSILE OFF on.

NO 1	NO 2
<p>Set main switch to OPERATION.</p> <p>Switch on cabin light (right).</p> <p>Check that LED indicators for 115/200 V 400 Hz and 26.5 V DC are on.</p> <p>Actuate switch LAMP TEST and check Light-emitting Diodes (LEDs) on main distributor.</p>	<p>Switch on cabin light (left).</p> <p>Switch on air conditioning (if necessary).</p>

NO 1	NO 2
<p>Check that after the start up test (approximately 60 seconds) the lamps TROUBLE COMPUTER and TROUBLE SUBSYSTEM are off.</p> <p>Press LAMP TEST and check that the indicator and pushbutton lamps on the operator console are on (keypads excepted) and glow at the same intensity.</p> <p>Check that indicators for trouble, warning, safety and subsystems are off.</p> <p>Press RADAR SILENCE X, RADAR SILENCE KA and DESIGNATION AUTO OFF (lamps on).</p> <p>Adjust Plan Position Indicator (PPI) picture with knob BRIGHTNESS.</p> <p>Press MENU (the main menu is displayed).</p>	<p>Press LASER DISABLE (lamp on).</p> <p>Adjust television (TV) picture with knobs BRIGHTNESS and CONTRAST.</p> <p>Turn potentiometer SIGNALTONE VOLUME clockwise to halfway position.</p>

OPERATIONAL READINESS CHECK

7. The Operational Readiness Check (ORC) tests all the important tactical functions of the FCU. It can be executed completely or by unit. At the beginning of every operating period and at the start of each operator shift, the LAMP TEST and the complete ORC must be performed to verify operational readiness of the equipment. Pressing the pushbutton AUXILIARY MODE interrupts the ORC and sets the FCU into combat state.

NO 1
<p>Select Menu 3/1—ORC COMPLETE</p> <p>Follow the instructions that appear on the display. A running check is indicated by a moving symbol (*< - >*) in the lower part of the PDM.</p> <p>In case of error a message is displayed, the pushbutton TROUBLE SUBSYSTEM blinks and instructions for further steps will be shown on the display.</p> <p>All errors detected during the ORC are stored in the computer. At the end of the ORC the stored errors can be called up by pressing the blinking pushbutton TROUBLE SUBSYSTEM.</p> <p>At the start of a new operator shift, press pushbutton LAMP TEST and check if the indicator and pushbutton lamps on the operator console are on (keypads excepted) and glow at the same intensity.</p>

ENTER DATE AND TIME

8. The system date and time for the FCU and the character brightness of the PDM may be set or changed. If a new date or time is set, all Identification Friend or Foe (IFF) codes will be deleted.

NO 1	
<p>Select Menu 13—DATE AND TIME</p>	
<p>Date</p>	<p>Enter numerical value</p>
<p>Time</p>	<p>Enter numerical value</p>
<p>Start System Time</p>	<p>Press YES</p>
<p>PDM Character Brightness</p>	<p>Select 100%, 75%, 50% or 25%</p>

DATA FOR X-BAND SEARCH RADAR

NO 1	
Select Menu 5/1—X SEARCH RADAR	
Select field where status is to be modified and key in the new settings	
Jammed Frequencies	Displays jammed frequencies (0, 1) 0 = not jammed 1 = jammed
Frequency Selection	Displays blocked and released frequencies (0, 1) 0 = blocked 1 = released
Frequency	Enter frequency number to be blocked or released (1 to 20)
Block This Frequency	Enter (YES) = blocked Enter (NO) = released
Auto Release of Blocked Frequencies	Enter (NO) in peace time to prevent releasing blocked frequencies
Moving Target Indication (MTI) Mode	Enter (YES) or (NO)

NO 1	
Sensitivity Time Control (STC) Range	Enter a range where fixed echoes are barely visible on PPI (1520 to 15200 m)
Constant False Alarm Rate (CFAR)	Enter (YES) or (NO) (See Note)
NOTE	
Set CFAR to NO and depress button Staggered Pulse Repetition Frequency (STAG PRF) (lamp on) to determine the number of second-time-around targets in the priority sectors on the PPI. If too many echoes are visible, STAG PRF mode is not allowed and must be reset. Reset CFAR to YES.	
Search Mode	The actual search mode is indicated. Selected on the control panel PPI via pushbutton FAST FREQUENCY CHANGE, STAG PRF, DSA BURST.
Track-While-Scan (TWS) First Target Alarm	Enter (YES). The first target appearing on the PPI triggers an acoustic alarm.
TWS Track Initialisation	Enter (Auto, Manual). Flight traces are automatically initialized and displayed on the PPI. Threat evaluation is operational.
Near Limit	Enter minimum range for TWS target (1 to 20 km).
PPI Range	Select 10, 16.6, 20 or 25 km.

NO 1	
PPI Marker On	Enter (YES). Range rings are displayed on the PPI screen.
Search Radar Data Extractor (SRDE) Function	<p>Select (Clutter Mapping) or (Sector Masking).</p> <p>Select (Mask Mode) or (Unmask Mode) in Field Mode selection.</p> <p>Press SRDE MASK/UNMASK and move tracking ball to mask or unmask clutter areas on the PPI.</p> <p>Select (Clutter Mapping) or (Sector Masking).</p> <p>Select (Mask Mode) or (Unmask Mode).</p> <p>Press SRDE MASK/UNMASK and move tracking ball to mask or unmask sectors on the PPI.</p>
Tracking Ball	Displays actual azimuth angle value from tracking ball mark on the PPI.
Mode Selection	Select (Mask Mode) or (Unmask Mode) corresponding to selected SRDE function.

NO 1	
Clear All	Enter (YES). All masked areas and sectors are cleared after one search radar antenna rotation.
NOTES	
<p>1. The STC function suppresses ground clutter in the immediate vicinity of the radar by reducing the receiver sensitivity. The STC range selected should always be as low as possible.</p> <p>2. Depress button CHANGE TRANSMITTER FREQUENCY or FAST FREQUENCY CHANGE to accept selected, released or blocked frequencies.</p>	

WARNING

The x-band search radar frequencies selected will not be activated unless the pushbutton "change transmitter frequency" is depressed or the target designation is activated.

DATA FOR X-BAND TRACKING RADAR

NO 1	
Select Menu 5/2— X-TRACKING RADAR Select field where status is to be modified and key in the new setting Power Distribution	

NO 1	
Tracking Radar/Search Radar	Select (Internally: 100%/0%), (50%/50%), (10%/90%) or (0%/100%).
MTI Mode	Select (MTI Auto), (MTI On) or (MTI Off).
MTI is	Displays MTI mode momentarily used (ON, OFF).
STC Range	Enter the same value as used for the search radar (1520 to 15200 m).
NOTE	
The STC function suppresses ground clutter in the immediate vicinity of the radar by reducing receiver sensitivity. The STC value selected should always be as low as possible.	

DATA FOR KA-BAND TRACKING RADAR

NO 1	
<p>Select Menu 5/3—KA— TRACKING RADAR</p> <p>Select field where status is to be modified and key in the new settings</p> <p>Jammed Frequencies</p>	<p>Displays jammed frequencies (0, 1)</p> <p>0 = not jammed</p> <p>1 = jammed</p>

NO 1	
Frequency	Enter frequency number to be blocked or released (1 to 20)
Block This Frequency	Enter (YES) = blocked Enter (NO) = released
Auto Release of Blocked Frequencies	Enter (NO) in peace time to prevent releasing blocked frequencies
MTI Mode	Select (MTI Auto), (MTI On) or (MTI Off)
MTI is	Displays MTI mode momentarily used (On, Off)
STC Range	Check if default value is set (3054 m)

DATA FOR ELECTRO-OPTICAL GROUP

NO 1	
Select Menu 5/4—ELECTRO-OPTICAL GROUP (EOG)	
Verify that all default values are as listed below. If this is not so, press DP on the keypad	
Crosshair On:	(No)
Lamp On:	(No)
Sun Shutter On:	(No) Sun Shutter is: (Off)

NO 1		
Calibration On:	(No)	Calibration Finished: (Yes)
		Zoom Position is: (150)
Video Tracker (VT)		
Crosshair On:	(No)	
Gate:	(Auto)	Gate Size:
Tracking Error Unit (TEU) Image Difference On:	(No)	
Test Image On:	(No)	
Video Display Generator (VDG)		
Crosshair On:	(Yes)	
Sensor Marks Visible In:	(Yes)	
TV Gate:		

DATA FOR LASER

NO 1	
Select Menu 5/5/1— OPERATING MODE OF LASER	
Time Variable Gain (TVG) On	(YES, NO) Change of setting not by the operator
State (Temperature Alarm)	Displays actual state of the laser module

NO 1	
Displays actual laser operating temperature:	
No Alarm	= Normal temperature
Pre-Warning	= High temperature
Half PRF	= Excessive temperature, results in automatic reduction of Pulse Repetition Frequency (PRF)
Laser Off	= Critical temperature, results in automatic shut down

NO 1	NO 2
<p>"LASER, SECTOR 1(2)"</p> <p>Select Menu 5/5/2—LASER SECTORS (EOG)</p> <p>Left Limit OK: Enter (YES)</p> <p>Left limit is (displays actual value) (repeat for other limits)</p> <p>Store Laser Sector 1(2): Enter (YES)</p>	 <p>Move tracker with joystick to the left limit—"LEFT LIMIT SIGHTED ON"</p> <p>(REPEAT FOR OTHER LIMITS)</p>

Fire Control Unit (FCU)—Coming Into Action

NO 1	NO 2
"LASER SECTOR 1(2) STORED"	

NO 1
<p>Select Menu 5/5/3— LASER SECTORS (MANUALLY)</p> <p>LASER SECTOR 1</p> <p>Left Limit</p> <p>Right Limit</p> <p>Upper Limit</p> <p>Lower Limit</p> <p>Store Laser Sector Enter (YES)</p> <p>Repeat the procedure for Laser Sector 2</p>
<p style="text-align: center;">NOTE</p> <p>Values are referenced to the keyed-in north direction.</p>

NO 1	NO 2
<p>"READ IN LASER PROFILE"</p> <p>Select Menu 5/5/4—LASER PROFILE</p>	

NO 1		NO 2
Profile:	Select (Read In)	Move tracker with the joystick along the designated profile on the TV monitor, "END OF PROFILE"
Start:	Enter (YES)	
"START PROFILE"		
Stop:	Enter (YES)	
Check displayed profile		
Reset Profile To:	Enter numerical value (-150 to 400 mils)	
Store Profile:	Enter (YES)	
Azimuth:	Displays actual tracker angle	
Elevation Angle:	Displays actual tracker angle	
"CHECK THE LASER PROFILE"		

NO 1	NO 2
<p>Select Menu 5/5/4—LASER PROFILE</p> <p>Profile: Select (Check)</p> <p>Start: Enter (YES)</p> <p>The tracker follows the laser safety profile automatically</p> <p>Stop: Enter (YES)</p> <p>The tracker stops moving</p>	<p>Check the profile visually on the TV monitor while the tracker moves—"LASER PROFILE OK"</p>
<p>NOTE</p> <p>If laser safety profile check was not satisfactory, repeat profile read-in.</p>	

DATA FOR IDENTIFICATION FRIEND OR FOE (IFF)

9. Input options for the IFF code depend on the selected IFF mode:

		A	B	C	D
IFF Mode = M1	Octal	0..7	0..3	_____	_____
IFF Mode = M2I M3A	Octal	0..7	0..7	0..7	0..7

10. The active IFF code (depending on date and time) will be displayed blinking.

11. Undefined IFF codes are displayed with a line "_____".

12. Any input in the IFF code table which is different from the previous value will set the whole line into "new input" state. After that input, it is expected that the code will be confirmed, otherwise it will not be recognised.

13. After each input, the code table will be sorted according to date and time.

14. If a code with a certain date and time has expired, the status will be set to "expired".

NO 1	
Select Menu 5/6	
Select field where status is to be modified and key in new settings	
Interrogation:	Select interrogation mode (all targets, TWS targets or manual)
All Targets	Interrogation of all targets acquired by the search radar
TWS Targets	Interrogation of targets stored in the track table
Manual Only	Interrogation of all targets by pressing pushbutton IFF INTERROG MANUAL
State is:	Displays actual IFF state
M4 Mode On	Enter (YES, NO)
Selective Identification Feature (SIF) Mode	Select (None, M1, M2 or M3A)
Select SIF Code	Select (Brackets, Code 1, Code 2, Code 1 or 2, Memory Module or Emergency)
Zulu Time M4	} Displays time pre-programmed in the memory module
Zulu Time SIF	

NO 1	
Code 1, Code 2:	Displays actual valid SIF code
Date/Time	Enter date and time determining the beginning of a new code validity
Code 1/Code 2	Enter numerical value (M1:00-77, M2/M3A:0000-7777)
Confirm	Enter (YES) to confirm setting in the corresponding line
State:	Displays actual state
Confirmed Blinking	Active
Confirmed On	Available
Expired On	Expired

NORTH ORIENTATION

15. North orientation evaluates the azimuth angle between north direction and the FCU trailer longitudinal axis. North is required as reference for all position data and the wind direction. North orientation can be performed with a reference point or with a

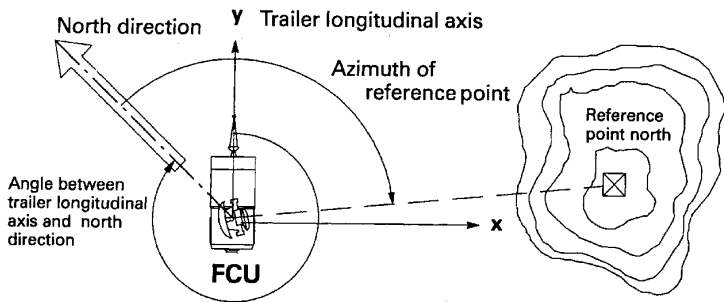

theodolite.

Figure 3-1: Definitions of Terms in North Orientation With Reference Point

16. Azimuth angle of reference point can be measured either by Aiming Circle or compass from the position of the FCU or on a map.

NO 1	NO 2
<p>"NORTH ORIENTATION WITH REFERENCE POINT"</p> <p>Select Menu 6/1—NORTH ORIENTATION WITH REFERENCE POINT</p> <p>Enter azimuth angle of reference point</p> <p>Confirm TV is sighted on, enter (YES)</p> <p>"NORTH ORIENTATION FINISHED"</p>	<p>"NORTH ORIENTATION"</p> <p>Sight on reference point north "REFERENCE POINT SIGHTED ON"</p>
<p style="text-align: center;">NOTE</p> <p>After a new north orientation, all positions related to north will be updated. North on the PPI is always upwards.</p>	

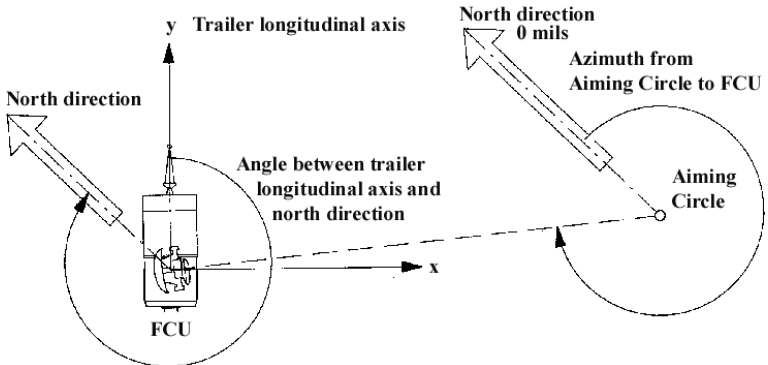

Figure 3-2: Definitions of Terms in North Orientation with Aiming Circle

NO 1	NO 2	NO 3
<p>"NORTH ORIENTATION WITH AIMING CIRCLE"</p> <p>Select Menu 6/2—NORTH ORIENTATION WITH AIMING CIRCLE</p> <p>Confirm TV is sighted on, enter (YES)</p> <p>Enter azimuth value</p>	<p>"NORTH ORIENTATION"</p> <p>Sight on the Aiming Circle optics</p> <p>" AIMING CIRCLE SIGHTED ON"</p>	<p>"NORTH ORIENTATION"</p> <p>Set up Aiming Circle about 200 m from FCU</p> <p>Orient Aiming Circle with 0 mils to north</p> <p>Sight on the white cross on the tracker</p> <p>Read the azimuth and report to FCU</p> <p>"AZIMUTH ... MILS"</p>

NO 1	NO 2	NO 3
Open door and inform OS by holding up one arm (north orientation finished)		
<p style="text-align: center;">NOTE</p> <p>After a new north orientation, all positions related to north will be updated. North on the PPI is always upwards.</p>		

DEFINITION OF REFERENCE POINTS WITH EOG

17. Reading reference point data into the computer enables a quick orientation check of the FCU because these reference points can be sighted on automatically at any time.

18. **Preparation.** Select suitable reference points in the surrounding terrain and determine the range.

19. The positions of the weapons are automatically stored in memory during weapon orientation.

NO 1	NO 2
<p>"SIGHT ON REFERENCE POINT"</p> <p>Select Menu 7/1— DEFINITION OF REFERENCE POINTS (EOG)</p> <p>Select reference point</p>	<p>Select suitable zoom position</p> <p>Sight on reference point exactly</p>

NO 1	NO 2
<p>Confirm TV sighted on reference point, enter (YES)</p> <p>Enter horizontal distance</p> <p>Store reference point</p>	<p>"REFERENCE POINT SIGHTED ON"</p>
<p style="text-align: center;">NOTE</p> <p>Definition of reference points can also be done manually in Cartesian, polar or cylindrical coordinates. To do so, select the corresponding menu and enter data.</p>	

INSPECTION OF REFERENCE POINTS

NO 1	NO 2
<p>Select Menu 7/5— INSPECTION OF REFERENCE POINTS</p> <p>"INSPECTION REFERENCE POINT..."</p> <p>Select number of reference point</p> <p>Press ENTER</p> <p>The tracker moves to aim at the selected reference point</p> <p>The coordinates are displayed in the table</p>	<p>"REFERENCE POINT SIGHTED ON"</p>

NO 1	NO 2	NO 3
<p>"ATTENTION, OS ORIENTATION WITH FCU"</p> <p>Select Menu 8/2— OS ORIENTATION WITH FCU</p> <p>Select OS to be oriented</p> <p>Confirm OS sighted on TV and TV sighted on by OS, enter (YES)</p> <p>Enter distance to OS</p> <p>Store position of OS</p> <p>"OS ORIENTATION FINISHED"</p>	<p>Select suitable zoom position</p> <p>Sight on collimator of OS</p>	<p>Measure distance FCU to OS using a measuring tape</p> <p>Check levelling</p> <p>Sight on white cross of TV camera (do not press the button)</p> <p>"FCU SIGHTED ON, DISTANCE ... M"</p>

OS ALIGNMENT CHECK

NO 1	NO 2	NO 3
<p>"ATTENTION, OS ALIGNMENT CHECK, REFERENCE POINT NO ..."</p> <p>Select Menu 8/3— OS ALIGNMENT CHECK</p> <p>Select OS to be used</p> <p>Select reference point "DESIGNATE"</p> <p>Compare displayed data</p> <p>Check the deviation</p> <p>"ALIGNMENT CHECK FINISHED"</p>		<p>"ALIGNMENT CHECK, REFERENCE POINT NO ..."</p> <p>Sight on reference point</p> <p>Press ON TARGET briefly</p> <p>"REFERENCE POINT SIGHTED ON"</p>
<p style="text-align: center;">NOTE</p> <p>Repeat orientation if deviation in azimuth is greater than 20 mils.</p>		

PREPARATION OF SKYGUARD FOR TRAINING SIMULATOR 2 (TS 2)

21. Connect Skyguard and TS-2 according to TS-2 Operation and Care Manual (refer to C-79-207-000/MB-001).

TS 2 OPERATOR	PPI OPERATOR
<p>Select Menu 5—ALIGNMENT</p> <p>"SKYGUARD 1 (2) PREPARE FOR TS 2"</p>	<p>"SKYGUARD 1 (2) PREPARE FOR TS 2"</p> <p>Select Menu 3/5/4/2</p> <p>Align VT crosshairs</p> <p>Select Menu 3/5/4/4</p> <p>Align VDG crosshairs</p> <p>Select Menu 5/1</p> <p>Open at least two frequencies</p> <p>Set NEAR LIMIT to 2000 m</p> <p>Set PPI RANGE to 20 km</p> <p>Select Menu 8/2</p> <p>Set DISTANCE TO OS to 0 m</p> <p>STORE POS OF OS: Yes</p> <p>Select Menu 9/1</p> <p>Set W1 and W2 to GDF 005</p> <p>Set AUTO GUN ALARM to ON</p> <p>Select Menu 9/3/4</p> <p>Set all values to 0</p> <p>MARK POS OF WEAPON AS DEFINED—YES</p> <p>Select Menu 12/2/2</p>

TS 2 OPERATOR	PPI OPERATOR
	<p>Set STORE SECTOR to NO for all sectors, weapons, W1 and W2</p> <p>Select Menu 14/5</p> <p>Set LOWER LIMIT to 0 mils</p> <p>Select Menu 2/1</p> <p>STAND BY IN TACTICAL DISPLAY, YES</p> <p>Set toggle switch RADAR X to OFF</p> <p>Set toggle switch RADAR Ka to OFF</p> <p>Set toggle switch LASER to OFF</p> <p>Press RADAR SILENCE X (lamp off)</p> <p>Press RADAR SILENCE Ka (lamp off)</p> <p>Set toggle switch IFF OFF to OFF</p> <p>Ensure lamp AUTO FIRE TO MISSILE OFF is on</p> <p>Report "SKYGUARD 1 (2) READY"</p>

CHAPTER 4

SKYGUARD SECTION—COMING INTO ACTION

1. The sections of this part are arranged in the sequence which must be followed in order to complete all tasks necessary for correct preparation of the Skyguard Section.

WARNING

1. To avoid accidents during preparation of the Skyguard Section, always ensure the following:
 - a. Lamp LASER DISABLE on;
 - b. Lamp RADAR SILENCE X on;
 - c. Lamp RADAR SILENCE KA on; and
 - d. Lamp AUTO FIRE TO MISSILE off.

COMMUNICATION, POWER SUPPLY UNIT (PSU) RUN UP AND DATA TRANSMISSION CHECK

2. The following checks must be carried out at the beginning of operations within the Skyguard Section, after a shift change, and after a change of detachment.

NO 1	NO 3	GUN 1	GUN 2
Press TALK OS while announcing "ATTENTION COMMUNICATION CHECK OS"	Press talk button while answering "OS OK"		

NO 1	NO 3	GUN 1	GUN 2
<p>Press TALK WEAPON while announcing "ATTENTION COMMUNICATION CHECK"</p> <p>"GUN 1 REPORT"</p> <p>"GUN 2 REPORT"</p> <p>"ATTENTION PSU RUN UP AND DATA TRANSMISSION CHECK"</p> <p>"ALARM GUNS"</p> <p>Verify on Plasma Display Monitor (PDM) that GUN 1(2) displays READY</p>	<p>Press ALARM GUN button once</p>	<p>"GUN 1 Comms OK"</p> <p>"GUN 1 READY"</p> <p>"GUN 1 OK"</p>	<p>"GUN 2 Comms OK"</p> <p>"GUN 2 READY"</p> <p>"GUN 2 OK"</p>

NO 1	NO 3	GUN 1	GUN 2
"COMMUNICATION CHECK FINISHED"	Press ALARM GUN button twice		
<p style="text-align: center;">NOTE</p> <p>If transmission fails, check field wires and circuit breakers.</p>			

ENTER WEAPON DATA

NO 1	
<p>Select Menu 9/1—WEAPON CONFIGURATION</p> <p>Type of Weapon 1</p> <p>Confirmed</p> <p>Type of Weapon 2</p> <p>Confirmed</p> <p>Weapon 3 and 4 are not connected</p> <p>Automatic Gun Alarm for All Slave Weapons</p>	<p>Select (GUN GDF 005 MV, No Weapon)</p> <p>Enter (Yes)</p> <p>Select (GUN GDF 005 MV, No Weapon)</p> <p>Enter (Yes)</p> <p>Select (Mode On, Mode Off), alarm when Skyguard is tracking a target at a range of less than 10 km</p>
<p>Select Menu 9/2—TECHNICAL DATA FOR WEAPON</p> <p>Insert Weapon (1...2)</p>	<p>Enter (1 or 2)</p>

NO 1	
Type	Display of the input from Menu 9/1 (GUN GDF 005 MV, No Weapon)
Autonomous	Enter (Yes, No)
Ammunition	Select (AHEAD, HEI, TP-T or SRTP-T)
Initial Velocity (VO)	Enter numerical value (900 to 1200 m/s for AHEAD, 1000 to 1200 m/s for other types)
Fire Duration	Enter numerical value (0.2 to 2.5 secs)
NOTE	
At least one gun must be configured and oriented in order to acquire and track targets.	

WEAPON ORIENTATION

3. The FCU computer program takes into account displacement (parallax) between the FCU and weapons in computing weapon lead angles.
4. Computation of parallax values (lateral and vertical displacement) is based on slant range, azimuth and elevation angle. Orientation consists of determining these values and reading in the weapon position.
5. In the case of visual contact between the FCU and a weapon, parallax values are measured automatically and the weapon is directly oriented.
6. If there is no visual contact between the FCU and the weapon, the weapon can be oriented indirectly using the theodolite.

7. If the range between the FCU and the weapon is greater than 500 metres, exact range is determined either from the map, with the measuring tape or Troop Ranger, or by the intersection method (not applicable for guns).
8. Weapons orientation using the Cartesian, polar or cylindrical system of coordinates is also possible but not applicable for guns. Therefore, these orientation procedures are not described.

NOTE

To repeat weapon orientation, the weapon must first be in an undefined position. To undefine a weapon, NO must be entered in Menu 9/3/1 at line - Store Position of Weapon.

DIRECT ORIENTATION

9. The FCU and weapon sight each other. The FCU measures the angles and the slant range to weapon automatically, with the Distance Measuring Device (DMD) sighting a reflector installed on the weapon.

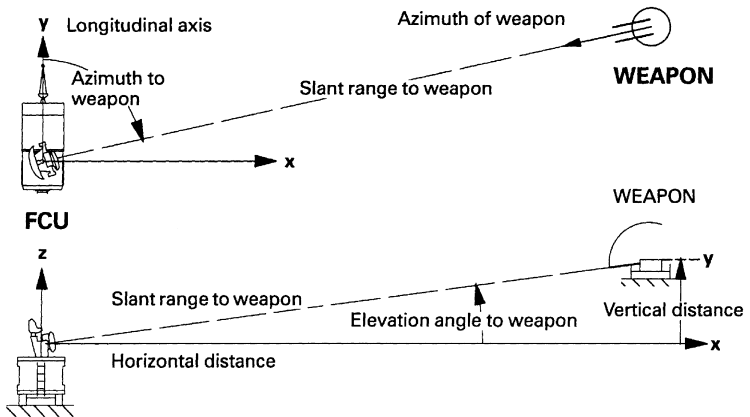

Figure 4-1: Definitions of Terms Used in Direct Orientation

NO 1	NO 2	GUN OPERATOR
<p>"ATTENTION GUN 1(2) DIRECT ORIENTATION"</p> <p>Select Menu 9/3/1— ORIENTATION OF WEAPON (DMD DIRECT)</p> <p>Select weapon</p> <p>Confirm sightings, enter (Yes)</p> <p>Check the automatically measured values</p> <p>Store position of weapon, enter (Yes)</p> <p>"GUN 1(2) ORIENTATION FINISHED"</p>	<p>Select suitable zoom position</p> <p>Sight on reflector at the gun</p> <p>"GUN 1(2) SIGHTED ON"</p>	<p>"GUN 1(2) DIRECT ORIENTATION"</p> <p>"FCU SIGHTED ON"</p> <p>"GUN 1(2) ORIENTATION FINISHED"</p>
<p style="text-align: center;">NOTE</p> <p>If an azimuth reading from the weapons or automatic distance measurement are not available, the required values can be keyed in manually.</p>		

INDIRECT ORIENTATION

10. If there is no visual contact between the FCU and weapon, the weapon can be oriented using an Aiming Circle. The Aiming Circle is set up at a place where both the FCU and the weapon can be seen. To measure the distance between the FCU and the Aiming Circle automatically with the DMD, a reflector is installed on a tripod next to the Aiming Circle. If it is not possible to acquire the distance automatically via the DMD, distance can be measured using the Troop Ranger and then keyed in manually.

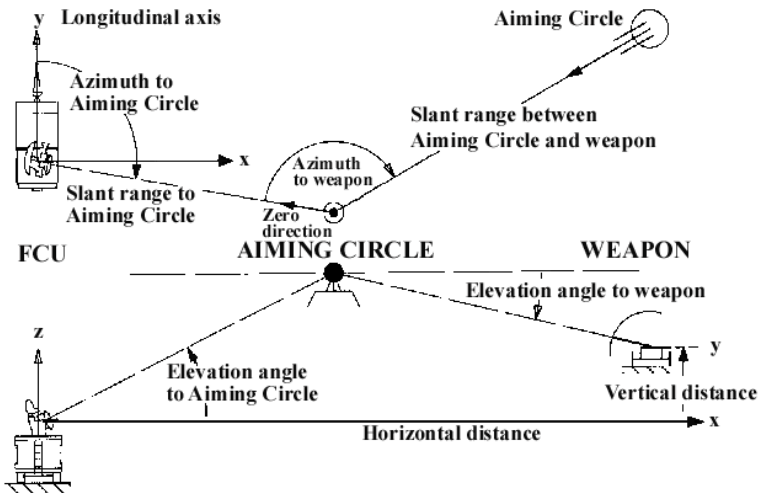

Figure 4-2: Definitions of Terms Used in Indirect Orientation

NO 1	NO 2	NO 3	GUN OPERATOR
<p>Order OS Operator with Aiming Circle, Troop Ranger and reflector to suitable site</p> <p>"ATTENTION GUN 1(2) INDIRECT ORIENTATION"</p> <p>Select Menu 9/3/2— ORIENTATION OF WEAPON (DMD INDIRECT)</p> <p>Select weapon</p>	<p>Select suitable zoom position</p> <p>Sight on reflector and report "REFLECTOR SIGHTED ON"</p>	<p>Set up one tripod with the Aiming Circle and the other with a reflector facing towards the tracker (ensure that both tripods are in close proximity to each other)</p> <p>Level Aiming Circle</p> <p>Orient Aiming Circle with 0 mils to the FCU</p>	<p>"GUN 1(2) INDIRECT ORIENT"</p>

NO 1	NO 2	NO 3	GUN OPERATOR
<p>Confirm FCU sighted on reflector, enter (Yes)</p> <p>Check the displayed slant range</p> <p>Open door and inform OS Operator (hold up hand)</p> <p>Confirm FCU sighted on Aiming Circle, enter (Yes)</p> <p>Enter 0 mils for azimuth from Aiming Circle to FCU</p> <p>Open door and inform OS Operator (hold up hand)</p> <p>"ATTENTION GUN 1(2) SIGHT ON AIMING CIRCLE"</p>	<p>Sight on Aiming Circle</p>	<p>Replace reflector with Troop Ranger</p>	<p>"GUN 1(2) SIGHT ON AIMING CIRCLE"</p>

NO 1	NO 2	NO 3	GUN OPERATOR
<p>Confirm weapon sighted on Aiming Circle, enter (Yes)</p> <p>Enter elevation angle</p> <p>Enter azimuth to weapon</p> <p>Enter slant range between Aiming Circle and weapons</p> <p>Store position of weapon, enter (Yes)</p>		<p>Sight on reflector at Gun 1(2)</p> <p>Read off elevation angle</p> <p>Read off azimuth to weapon</p> <p>Using Troop Ranger, measure slant range to Gun 1(2)</p> <p>Report all data to the No 1</p>	<p>Look through optical system and sight on optics of Aiming Circle</p> <p>"AIMING CIRCLE SIGHTED ON"</p>

NO 1	NO 2	NO 3	GUN OPERATOR
"GUN 1(2) ORIENTATION FINISHED"			"GUN 1(2) ORIENTATION FINISHED"
<p style="text-align: center;">NOTE</p> <p>If automatic readings of the slant range from the FCU to the theodolite and the azimuth of the weapon are not available, these values can also be entered manually.</p>			

ALIGNMENT CHECK

11. Carry out the alignment check with at least two reference points. If deviation for azimuth or elevation exceeds 2 mils at the gun, repeat weapon orientation.

NO 1	NO 2	GUN OPERATOR
<p>"ATTENTION GUN 1(2) ALIGNMENT CHECK, REFERENCE POINT NO..."</p> <p>Select Menu 10— ALIGNMENT CHECK</p> <p>Select reference point</p> <p>Let guns sight on reference point, enter (Yes)</p> <p>"ALARM GUN"</p>	<p>Check that reference point is sighted on exactly</p> <p>Press ALARM GUN once</p>	<p>"GUN 1(2) ALIGNMENT CHECK, REFERENCE POINT NO..."</p> <p>Switch to REMOTE</p>

NO 1	NO 2	GUN OPERATOR
<p>"REPORT DEVIATION"</p> <p>Enter the deviation</p> <p>"ALIGNMENT CHECK FINISHED"</p>	<p>Press ALARM GUN twice</p>	<p>"DEVIATION GUN 1(2), AZIMUTH (LEFT/RIGHT)...MILS AND ELEVATION (UP/DOWN)...MILS"</p> <p>Switch to LOCAL</p> <p>"GUN 1(2) ALIGNMENT CHECK FINISHED"</p>

ZERO TEST

12. The Zero Test is designed as a dynamic orientation check and a check of weapon control and target tracking without dynamic and ballistic prediction calculations.

NOTE

The Zero Test can only be performed when the target is within 6 kilometres and visible to the gun operator.

NO 1	NO 2	GUN OPERATOR
<p>"ATTENTION GUN 1(2) ZERO TEST"</p> <p>Select Menu 14/4—PRE-SELECTION OF AUXILIARY MODES</p>		<p>"GUN 1(2) ZERO TEST"</p>

NO 1	NO 2	GUN OPERATOR
Select Zero Test Exit from menu Lock on target "ALARM GUN" "REPORT DEVIATION" Write down range and deviation "ZERO TEST FINISHED" Press AUXILIARY MODE	Press ALARM GUN once Press ALARM GUN twice	Switch to REMOTE Report at different ranges "GUN 1(2), AZIMUTH (LEFT/RIGHT)...MILS AND ELEVATION (UP/DOWN)...MILS" Switch to LOCAL "GUN 1(2) ZERO TEST FINISHED"

FICTITIOUS TARGET FIRING WITH GUNS

13. Firing at fictitious targets verifies orientation accuracy and ballistics, including Muzzle Velocity (MV) and meteorological data. The reference point used must be inside the firing sector. It is suggested that the reference point be stored as number 16, with a horizontal distance of 1500 metres and an elevation angle of 400 mils.

NOTE

Whenever possible, carry out fictitious target firing with live ammunition to ensure the functioning and accuracy of the complete integrated Skyguard Section in accordance with the procedure outlined below. If permission for live firing is not granted, the same procedure must be followed to ensure functioning of the gun fire trigger actuation from the FCU.

NO 1	NO2	GUN OPERATOR
<p>"ATTENTION GUN 1(2) PREPARE FOR FICTITIOUS TARGET FIRING"</p> <p>Select Menu 14/2— FICTITIOUS TARGET FIRING WITH GUNS</p> <p>Select reference point 16</p> <p>Check the reference point data</p> <p>Confirm selected reference point, enter (Yes)</p> <p>"ALARM GUN"</p> <p>Confirm positioning is completed and gun data are correct, enter (Yes)</p>	<p>Check if television (TV) picture is OK</p> <p>Press ALARM GUN once</p>	<p>"GUN 1(2) FICTITIOUS TARGET FIRING"</p> <p>Prepare gun for firing</p> <p>"GUN 1(2) READY FOR FICTITIOUS TARGET FIRING"</p>
<p>"ATTENTION FICTITIOUS</p>	<p>Press READY TO FIRE</p>	

NO 1	NO2	GUN OPERATOR
<p>TARGET FIRING 3, 2, 1, FIRE"</p> <p>"GUN 1(2) REPORT"</p> <p>"FICTITIOUS TARGET FIRING FINISHED"</p>	<p>FIRE</p> <p>Observe the TV monitor. The shell's echoes are visible on the range trace. When they are at the position of the range marker, the shells have reached target range and should be visible on the TV monitor within the TV gate.</p> <p>Press ALARM GUN twice</p>	<p>"GUN 1(2) BOTH BARRELS OK"</p> <p>"GUN 1(2) FICTITIOUS TARGET FIRING FINISHED"</p> <p>Switch to LOCAL</p>

METEOROLOGICAL DATA

14. The determination of meteorological data is described in Part 8. Any new input will also register the time of this update.

NO 1	
<p>Select Menu 11—METEO DATA</p> <p>Atmospheric Pressure</p> <p>Air Temperature</p> <p>Relative Humidity</p>	<p>Enter magnitude (600 to 1300 h Pa/mbar)</p> <p>Enter magnitude (-20 to +50°C)</p> <p>Enter (65%) (0 to 100%)</p>
	<p>Enter (90%) in rainy days</p> <p>Enter (35%) on cold and dry</p>

NO 1	
Actual Wind	days During balloon tracking— display of balloon speed and direction If not balloon tracking—enter numerical data
Ballistic Wind	Display of compensated values
Reset to Average Wind	Enter average wind speed and direction when not using the actual wind data for every layer, thus the measured values are voided
Last Updates	Display of the most recent data update

LOWER LIMIT FOR ACQUISITION

15. To determine the lowest elevation angle from which an air target can be expected, follow the outline of the surrounding terrain with the crosshair of the TV camera. The respective elevation angle is displayed on the TV monitor. Then input the lowest value as the lower limit for the elevation search movement during target acquisition.

NO 1	NO 2
"DETERMINE LOWER LIMIT OF SCAN" Select Menu 14/5— PARAMETERS FOR AUTO OPERATION	
	Use joystick to follow the terrain outline and read off the lowest elevation angle

NO 1	NO 2
Enter the lower limit for acquisition	Report "LOWER LIMIT...MILS"

POSITION OF OWN FCU

16. The values must be known or determined with the help of a map. The coordinates refer to the master coordinate system.

NO 1	
Select Menu 12/1— CARTESIAN POSITION OF OWN FCU	
X Coordinate	Enter numerical value (-40000 to +40000 m)
Y Coordinate	Enter numerical value (-40000 to +40000 m)
Z Coordinate	Enter numerical value (-10000 to +10000 m)
Store Position	Enter (Yes)

PRIORITY SECTOR LIMITS

17. Two priority sectors can be entered and displayed on the Plan Position Indicator (PPI). Targets entering these sectors are assigned a high priority in the threat evaluation. The sectors can be set via the Electro-Optical Group (EOG) or manually if the values of the limits are known.

NO 1	NO 2
------	------

NO 1	NO 2
<p>Setting with EOG:</p> <p>Select Menu 12/2/1—SITE DATA (EOG)</p> <p>Left Limit OK Enter (Yes)</p> <p>Right Limit OK Enter (Yes)</p> <p>Store Sector Enter (Yes)</p>	<p>Move the tracker with the joystick to the left priority limit</p> <p>Move the tracker to the right priority limit</p>
<p>Setting Manually:</p> <p>Select Menu 12/2/2—SITE DATA (MANUALLY)</p> <p>Left Limit Enter numerical value</p> <p>Right Limit Enter numerical value</p> <p>Store Sector Enter (Yes)</p>	

POSITION OF VITAL POINT

18. The position of the vital point can be entered via the EOG or manually in Cartesian, polar or cylindrical coordinates. The procedure using the EOG is described below.

19. For manual procedures, select the corresponding menu and enter the data. All data are referred to the FCU position.

NO 1	NO 2
Determine the horizontal distance with the help of a map Select Menu 12/3/1—POSITION OF VITAL POINT (EOG) Confirm TV camera on vital point, enter (Yes) Enter the horizontal distance Store vital point	Sight on vital point

POSITION OF NEIGHBOURING FCUS AND SURVEILLANCE RADAR

20. The values must be known or determined with the help of a map. The coordinates refer to the master coordinate system.

NO 1	
Select Menu 12/4—POSITION OF NEIGHBOURING FCUs X Coordinate Y Coordinate	Enter numerical values (-40 to +40 km) Enter numerical values (-40 to +40 km)

NO 1	
Z Coordinate	Enter numerical values 9-10000 to +10000 m)
Store Position	Enter (Yes)

Select Menu 12/5—POSITION OF SURVEILLANCE RADAR	
X Coordinate	Enter numerical values (-40 to +40 km)
Y Coordinate	Enter numerical values (-40 to +40 km)
Z Coordinate	Enter numerical values 9-10000 to +10000 m)
Store Position	Enter (Yes)

BATTERY COMMAND POST (BCP)

NO 1	
Select Menu 14/7 BATTERY COMMAND POST	
BCP Communication On	Enter (Yes) to establish data communication between the FCU and BCP
Alternate BCP Communication On	Enter (Yes) to establish data communication between FCU and Alternate BCP
Set First Priority BCP	Select (BCP or A/BCP)
Radio Voice Priority	Enter (Yes, No)

NO 1	
Override BCP Defined Sectors	Enter (Yes, No)
NO 2	
Set toggle switch DATA BCP to position UHF RADIO or WIRE as commanded	

TECHNICAL SKYGUARD SECTION CONFIGURATION

21. The display of the Skyguard Section configuration shows a summary of important technical parameters. The operator can reset all location and meteorological data.

NO 1
<p>Select Menu 4—FU CONFIGURATION</p> <p>Check the validity of all data</p> <p>Reset orientation (if necessary)</p> <p>Reset meteorological data (if necessary)</p> <p>If the data has been reset or has to be changed, determine and enter the new settings by selecting the corresponding menu.</p>

TACTICAL SKYGUARD SECTION CONFIGURATION

22. Before operating the Skyguard Section, the Section Commander has to ensure the following are satisfactory:

- a. communicating to own troop and to the BCP;
- b. personnel organization;
- c. readiness of equipment;

Skyguard Drill Book

- d. preparation and storage of ammunition;
- e. fuel supply;
- f. first aid organization;
- g. field fortification and camouflage; and
- h. posting of sentries.

CHAPTER 5 OPERATION MODES

1. The Fire Control Unit (FCU) detects and evaluates situations in the combat area. Appropriate measures and corresponding operating sequences are initiated automatically. This part deals with those conditions which require operator action. The following sections generally provide a brief description of observed operating conditions, then a table which prioritizes possible operator actions.

RAIN CLUTTER SUPPRESSION

2. Observation in the FCU. Rain Clutter on the Plan Position Indicator (PPI).

PRIORITY	WIDE FILTER	RAIN FILTER	CIRCULAR POLARIZATION	REMARKS
1	X			Search radar range is reduced to 20 km
2		X		Search radar range is reduced to 20 km
3			X	
X = Depress the corresponding pushbutton (ON)				

GROUND CLUTTER

3. **Observation in the FCU.** Ground clutter on the PPI, which misleads automatic target detection and automatic threat evaluation.

PRIORITY	WIDE FILTER	RAIN FILTER	CIRCULAR POLARIZATION	REMARKS
1	X			Search radar range is reduced to 20 km
2		X		Search radar range is reduced to 20 km, no helicopter classification
3			X	Sensitivity Time Control (STC) range can be set to the maximum in extreme cases
X = Depress the corresponding pushbutton (ON)				

DESIGNATION RADAR

4. Designation radar can be carried out in four different modes. The four different designation modes can be pre-selected by the operator by setting the Track While Scan (TWS) track initialization to Auto or Manual (refer to Section 3.8) and depressing the pushbutton DESIGNATION AUTO OFF to on or off.

MODE	TWS TRACK INITIALIZATION	LAMP DESIGNATION AUTO OFF
Designation Mode 1	Auto	Off
Designation Mode 2	Auto	On
Designation Mode 3	Manual	On

MODE	TWS TRACK INITIALIZATION	LAMP DESIGNATION AUTO OFF
Designation Mode 4	Manual	Off

DESIGNATION MODE 1

TWS Track Initialization: Auto Automatic Gun Alarm: Off

Lamp DESIGNATION AUTO OFF: Off

INDICATION	CONDITION	NO 1	NO 2
Target echo on PPI Distance less than 10 km DESIGN NEXT/RESET off	FCU locks on automatically to the first target detected by search radar FCU in tracking mode	"TARGET... KM"	No action Press ALARM GUN
<div style="border: 1px solid black; display: inline-block; padding: 2px;">1</div> Second target on PPI DESIGN NEXT/RESET blinking	FCU in tracking mode	"SECOND TARGET... KM"	Press DESIGN NEXT/RESET

DESIGNATION MODE 2

TWS Track Initialization: Auto Automatic Gun Alarm: Off

Lamp DESIGNATION AUTO OFF: On

INDICATION	CONDITION	NO 1	NO 2	
Target echo on PPI and DESIGN NEXT/RESET blinking	FCU locks on the most threatening target FCU in tracking mode and target distance less than 10 km	"TARGET...KM"	Press DESIGN NEXT/RESET Press ALARM GUN	
Second target on PPI <table border="1" data-bbox="213 980 288 1052" style="display: inline-table; vertical-align: middle;"> <tr> <td style="text-align: center;">2</td> </tr> </table> DESIGN NEXT/RESET blinking	2	FCU in tracking mode, another target is detected with a lower threat priority Target change to second target	"SECOND TARGET...KM"	Press DESIGN NEXT/ RESET twice after firing at first target
2				

INDICATION	CONDITION	NO 1	NO 2
<p data-bbox="213 277 263 329">1</p> <p data-bbox="270 240 373 362">DESIGN NEXT/ RESET blinking</p> <p data-bbox="213 646 378 732">DESIGN NEXT/RESET on</p>	<p data-bbox="421 402 586 610">Target change to the most threatening target, FCU tracks the most threatening target</p>		<p data-bbox="793 240 963 329">Press DESIGN NEXT/ RESET twice</p>
<p data-bbox="213 802 263 854">2</p> <p data-bbox="270 769 389 859">DESIGN NEXT/ RESET on</p>	<p data-bbox="421 769 591 919">FCU in tracking mode, the second target has lower threat priority</p> <p data-bbox="421 959 575 1049">Target change to second target</p>		<p data-bbox="793 959 963 1109">Press DESIGN NEXT/RESET twice after firing at first target</p>

DESIGNATION MODE 4

TWS Track Initialization: Manual Automatic Gun Alarm: Off

Lamp DESIGNATION AUTO OFF: Off

INDICATION	CONDITION	NO 1	NO 2
Target echo on PPI, distance less than 10 km DESIGN NEXT/RESET off	FCU locks on the target FCU in tracking mode	"TARGET... KM" Move tracking ball mark onto target Press MOST THREAT TARGET	Press ALARM GUN
Second target echo on PPI DESIGN NEXT/RESET off	FCU in tracking mode	"SECOND TARGET...KM" Move tracking ball mark onto second target Press MOST THREAT TARGET	
<div style="border: 1px solid black; display: inline-block; padding: 2px;">1</div> DESIGN NEXT/RESET blinking			Press DESIGN NEXT/RESET

INDICATION	CONDITION	NO 1	NO 2
DESIGN NEXT/RESET off	Target change to the most threatening target, FCU tracks the most threatening target		
<div style="border: 1px solid black; display: inline-block; padding: 2px 5px; margin-right: 5px;">2</div> DESIGN NEXT/ RESET on	FCU in tracking mode, the second target has lower threat Target change to second target		Press DESIGN NEXT/RESET after firing at first target

DESIGNATION OPTICAL SIGHT (OS)

5. The OS Operator follows a target and depresses the button OS ON TARGET until the Doppler tone sounds.

6. The indications in the FCU, and PPI and television (TV) Operator actions, are the same as for Designation Radar (refer to Section 5.3). Both designation modes depend on the selected Designation Modes (1 to 4) and the momentary FCU mode (reset or tracking).

7. The only difference between the two designation modes is that during designation via OS a cursor is generated on the PPI showing the azimuth of the designated target.

NOTE

A target designated by the OS always has the highest threat priority.

BROADBAND AND SPOT NOISE JAMMER

8. Observation in the FCU. Jammer azimuth indication on the PPI.

PRIORITY	CHANGE TRANSMITTER FREQUENCY	FAST FREQUENCY CHANGE	DSA BURST	MOST THREAT TARGET	DESIGN NEXT/RESET	SECTOR SEARCH KA	REMARKS
1	X						PPI Operator reports "JAMMER"
2		X					PPI Operator reports "JAMMER", no helicopter classification
3			X				PPI Operator reports "JAMMER", no helicopter classification
4				X	X		Move tracking ball mark onto jammer indicator, if FCU does not lock on after five seconds, use Priority 4
5					X	X	Move tracking

PRIORITY	CHANGE TRANSMITTER FREQUENCY	FAST FREQUENCY CHANGE	DSA BURST	MOST THREAT TARGET	DESIGN NEXT/RESET	SECTOR SEARCH KA	REMARKS
							ball mark onto jammer indicator
X = Depress the corresponding pushbutton (ON)							

BLINKING NOISE JAMMER

9. Observation in the FCU. Sporadic jammer azimuth indication on the PPI.

PRIORITY	CHANGE TRANSMITTER FREQUENCY	FAST FREQUENCY CHANGE	DSA BURST	MOST THREAT TARGET	DESIGN NEXT/RESET	SECTOR SEARCH KA	REMARKS
1	X						PPI Operator reports "JAMMER"
2		X					PPI Operator reports "JAMMER", no helicopter classification
3			X				PPI Operator reports "JAMMER", no helicopter classification

PRIORITY	CHANGE TRANSMITTER FREQUENCY	FAST FREQUENCY CHANGE	DSA BURST	MOST THREAT TARGET	DESIGN NEXT/RESET	SECTOR SEARCH KA	REMARKS
4				X	X		Refer to Section 5.3.3 if the target is sporadically visible on the PPI
5					X	X	Move tracking ball mark onto jammer indicator
X = Depress the corresponding pushbutton (ON)							

INTERFERENCE

- 10. Observation on the PPI:
 - a. Interference on the PPI.
 - b. Many false target tracks on the PPI.
 - c. EXTRACTOR OVERLOAD and TWS OVERLOAD is indicated on the Plasma Display Monitor (PDM).

PRIORITY	CHANGE PRF	STAG PRF	CHANGE TRANSMITTER FREQUENCY	DSA BURST	REMARKS
1	X				
2		X			No helicopter classification
3			X		
4				X	No helicopter classification
X = Depress the corresponding pushbutton (ON)					

RANGE GATE STEALER

11. Range gate stealer does not degrade the search radar function. If all sensors are operational, range gate stealer is not effective against the tracking radar function due to automatic priority sensor selection (laser, Ka-Band radar).

NOTE

If only the X-Band radar is operational and tracking then fast range gate stealing is automatically rejected and slow pull-off deception may cause loss of target tracking.

INDICATION	NO 1	NO 2
On PPI. False echo blips with increasing range.	Press DSA BURST, reports "RANGE GATE STEALER"	

INDICATION	NO 1	NO 2
<p>On TV Monitor, left range trace. Second echo from centre moving upwards.</p> <p>Lamp MEMO on, display on text line 1: MEMO. Target disappears on range trace.</p>	<p>Press DSA BURST</p>	<p>Reports "RANGE GATE STEALER"</p> <p>Press DESIGN NEXT/RESET twice</p>

CHAFF

12. Observation in the FCU. Chaff clutter on the PPI.

PRIORITY	WIDE FILTER	RAIN FILTER	STAG PRF	REMARKS
1	X			Search radar range is reduced to 20 km
2		X		Search radar range is reduced to 20 km
3			X	No helicopter classification
X = Depress the corresponding pushbutton (ON)				

FALSE TARGET DECEPTIONS

13. Observation in the FCU. False target blips on the PPI.

PRIORITY	CHANGE TRANSMITTER FREQUENCY	DSA BURST	REMARKS
1	X		
2		X	No helicopter classification
X = Depress the corresponding pushbutton (ON)			

TRACKING MODES

14. The computer checks and compares sensor tracking data input continuously. In the TRACKING AUTO Mode, the sensors which are delivering coherent data are selected as input to the tracking formula according to predetermined priority criteria.

15. The operator can override the TRACKING AUTO Mode by depressing the following pushbuttons (providing the pushbutton lamps are on):

- a. TRACKING X;
- b. TRACKING KA;
- c. TRACKING TV; and
- d. LASER FIRE.

16. If in such a manually selected tracking mode the corresponding sensor data are no longer coherent, the system returns automatically to TRACKING AUTO Mode.

17. Only one of the sensors written in brackets can be used in computing the tracking formula at any given time. The sensors that do not appear in brackets are definitively selected.

MODE	NO 2	INDICATION	DISPLAY ON TEXT LINE 1 (ANGLE/RANGE)
Tracking Auto		TRACKING AUTO OFF (Off)	(TV, RADAR, KA, X)/ (LASER, KA, X)
Tracking TV	Press TRACKING TV when the lamp is on	TRACKING TV (On) TRACKING AUTO OFF (On)	TV/ (LASER, KA, X)
Tracking X	Press TRACKING X when the lamp is on	TRACKING X (On) TRACKING AUTO OFF (On)	X/X
Tracking Ka	Press TRACKING Ka when the lamp is on	TRACKING Ka (On) TRACKING AUTO OFF (On)	KA/KA
Tracking Laser	Press LASER FIRE when the lamp is on	LASER FIRE (On) TRACKING AUTO OFF (On)	(TV, KA, X) /LASER
Tracking Joystick	Press TRACKING JOYSTICK, follow the target with the joystick by keeping the TV gate around it	TRACKING JOYSTICK (On) TRACKING AUTO OFF (On)	JOY/ (LASER, KA, X)

TRACKING MEMORY

MODE	NO 2	INDICATION	DISPLAY ON TEXT LINE 1
MEMO (On)	<div style="border: 1px solid black; display: inline-block; padding: 2px; margin-bottom: 5px;">1</div> TV Operator notices that the target will soon disappear	Press MEMO until target reappears Release MEMO	MEMO
MEMO (Off)	Target reappears		ACTIVE or PASSIVE
	<div style="border: 1px solid black; display: inline-block; padding: 2px; margin-bottom: 5px;">2</div> Target disappears before the TV Operator realizes it The FCU switches automatically to tracking memory		MEMO

PASSIVE TRACKING

MODE	NO 2	INDICATION	DISPLAY ON TEXT LINE 1
Jamming is so strong that echo disappears on range trace	Press button CHANGE TRANSMITTER FREQUENCY	"PASSIVE"	PASSIVE
1 Jammer disappears			ACTIVE
1 Jammer remains	Press TRACKING TV	"PASSIVE"	ACTIVE or PASSIVE

FIRING

INDICATION	CONDITION	NO 2
FOLLOWING display on PDM	FOLLOWING is displayed on the PDM for all autonomous and non-autonomous guns in Slave Mode	Check the tracking performance and hit probability displayed on TV monitor

INDICATION	CONDITION	NO 2
READY TO FIRE blinking	Hit Probability: 0-30%	
READY TO FIRE (On)	Hit Probability: 30-100%	"FIRE"
	The guns are firing	Press READY TO FIRE
READY TO FIRE (Off)	The firing has stopped	Release READY TO FIRE
	After firing	Press DESIGN NEXT/RESET
DESIGN NEXT/RESET (Off)		Press ALARM GUN twice

AIR-TO-SURFACE MISSILE (ASM) ALARM

18. Lamp AUTO FIRE TO MISSILE OFF: (Off) allows automatic target lock-on and firing. In case of miss, manual firing is required.

19. Lamp AUTO FIRE TO MISSILE OFF: (On)

INDICATION	CONDITION	NO 2	DISPLAY ON TEXT LINE 1
Second target on range trace and PPI CHANGE TARGET FORMATION blinking	Tracked target fires an ASM		

INDICATION	CONDITION	NO 2	DISPLAY ON TEXT LINE 1
	Target change to acquire the ASM	Press CHANGE TARGET FORMATION	
<p style="text-align: center;">NOTE</p> <p>After switching on the FCU, the lamp AUTO FIRE TO MISSILE OFF is on. To switch off the lamp, press FIRE ENABLE first and then AUTO FIRE TO MISSILE OFF.</p>			

TARGET CHANGE WITHIN FORMATION VIA RANGE TRACE

INDICATION	CONDITION	NO 2
<p>Two target echoes on range trace</p> <p style="text-align: center;">CHANGE TARGET FORMATION blinking</p> <p style="border: 1px solid black; display: inline-block; padding: 2px;">1</p> <p>CHANGE TARGET FORMATION (On)</p>	<p>FCU in Tracking Mode</p> <p>Target change to the most threatening target, FCU tracks the most threatening target</p>	<p>Press CHANGE TARGET FORMATION</p>

INDICATION	CONDITION	NO 2
<p>2</p> <p>CHANGE TARGET FORMATION (On)</p>	<p>FCU in tracking mode, the second target has lower threat priority</p> <p>Target change to second target</p>	<p>Press CHANGE TARGET FORMATION after firing at first target</p>

TARGET CHANGE WITHIN FORMATION VIA TV MONITOR

INDICATION	CONDITION	NO 2
<p>1</p> <p>Two targets on TV monitor</p> <p>CHANGE TARGET FORMATION (On)</p>	<p>FCU in Tracking Mode (except tracking joystick)</p> <p>TV gate encloses target</p> <p>Tracking of first target is continuous, second target is tracked by TV</p>	<p>Depress ring on joystick and move TV gate to the second target</p> <p>Release joystick</p> <p>Press CHANGE TARGET FORMATION</p>

INDICATION	CONDITION	NO 2
<div style="border: 1px solid black; display: inline-block; padding: 2px; margin-bottom: 5px;">2</div> <p>TRACKING JOYSTICK (On), two targets on TV monitor</p> <p>CHANGE TARGET FORMATION (On)</p>	<p>FCU in Tracking Mode</p> <p>TV gate encloses target</p> <p>Tracking of first target is continuous, second target is tracked by TV</p>	<p>Depress ring on joystick and move TV gate to the second target</p> <p>Release joystick</p> <p>Press CHANGE TARGET FORMATION</p>

LOCAL TAKE-OVER AND REMOTE ACQUISITION OF NON-AUTONOMOUS GUN

20. Gun status has been defined as non-autonomous in Menu 9/2.

DISPLAY ON PDM	CONDITION	NO 1	GUN OPERATOR
<p>REMOTE FOLLOWING</p>	<p>FCU in Tracking Mode, GUN follows target in Remote Mode</p>	<p>"ATTENTION GUN 1(2), TAKE-OVER"</p>	<p>Carry out local take-over (refer to the Gun Drill Book)</p>

DISPLAY ON PDM	CONDITION	NO 1	GUN OPERATOR
LOCAL TRACKING	Gun follows target in Local Mode		
REMOTE FOLLOWING	Gun follows target in Remote Mode	"ATTENTION GUN 1(2) REMOTE"	Press pushbutton TRACKING

LOCAL TAKE-OVER WITH AUTONOMOUS GUN

- 21. Gun status has been defined as autonomous in Menu 9/2.
- 22. TWS track Initialization is set to Manual in Menu 5/1.
- 23. Lamp DESIGNATION AUTO OFF is (On).

INDICATION	DISPLAY ON PDM	NO 1	GUN OPERATOR
Target echo on PPI	READY LOCAL	Move tracking ball mark onto target	
WI(W2) NEXT/RESET (On), beam between target and gun symbol on PPI	LOCAL SEARCHING	Press INIT MAN TRACK Press W1(W2) NEXT/RESET	Alarm tone via intercom Press EXTERNAL ASSIGNMENT, gun follows in azimuth

INDICATION	DISPLAY ON PDM	NO 1	GUN OPERATOR
	<p>LOCAL TRACKING (On), display of the target data</p>		<p>Control gun in elevation with control yoke</p> <p>Release EXTERNAL ASSIGNMENT</p> <p>Press TRACKING</p>
<p style="text-align: center;">NOTE</p> <p>If target disappears from TWS, the message "TARGET DISAPPEARED" shows up instead of target data. Press W1(W2) NEXT/RESET to interrupt target designation to gun.</p>			

CHAPTER 6 COMING OUT OF ACTION

PREPARE TO MOVE

NO 1	NO 2	NO 3	NO 4	NO 5
<p>"PREPARE TO MOVE"</p> <p>(No 1 also passes prepare to move to the guns)</p> <p>Watch Plan Position Indicator (PPI)</p>	<p>Watch MONITOR</p>	<p>Remove Fire Control Unit (FCU) camouflage</p>		<p>Remove FCU camouflage</p>
<p>NOTE</p> <p>This drill can vary depending on the time remaining in action and also depends on unit standard operating procedures.</p>				

CEASE FIRING

NO 1	NO 2	NO 3	NO 4	NO 5
<p>"CEASE FIRING"</p> <p>(No 1 also passes cease firing to the guns and waits for "GUNS CLEAR")</p>				

NO 1	NO 2	NO 3	NO 4	NO 5
<p>Select Menu 4 to reset all data</p> <p>Press AUXILIARY MODE (ensure combat program)</p> <p>Press DESIGNATION AUTO OFF (lamp on)</p> <p>Press ZERO POSITION once and wait until search radar antenna is locked (lamp ZERO POSITION on)</p> <p>Set main switch to OFF</p>	<p>Ensure FCU is in reset mode</p> <p>Set toggle switch AIRCOND to OFF</p> <p>Remove tarpaulin behind bench (if necessary)</p>	<p>Retrieve Aiming Circle and Near Term Digital Radio (NTDR) antenna</p>	<p>Bring prime mover to position</p> <p>Load all stores on prime mover including fuel cans</p>	<p>Load all stores on prime mover</p>

NO 1	NO 2	NO 3	NO 4	NO 5
Remove all loose parts from cabin	Replace microphone into holding bracket			
Roll down operator console cover	Swing up hinged table	Disconnect Optical Sight (OS) cable at FCU and OS		
Release roof lock (right)	Release roof lock (left)	Fold in and lock outrigger with bearing		
Put bench in transport position	Put bench in transport position	Roll up OS cable and fasten it		
Ensure towbar is down	Set handle AZIMUTH to TRANSPORT	Lower adjustable column and lock in place		
Press PUMP ON	Disconnect field wires for weapons	Swing intercom station		
The lamps SAFETY ROOF and PUMP ON must be on		Put canopy hood over OS and fasten		
Clean roof, tracker and antenna of snow and/or ice		Swivel in outrigger with spindles		

NO 1	NO 2	NO 3	NO 4	NO 5
Press OPEN ROOF until roof is completely open				

NO 1	NO 2
<p>Set handle SEARCH ANTENNA to TRANSPORT</p> <p>Set handle ELEVATION to TRANSPORT</p> <p>Set handle TILT AXIS to TRANSPORT</p> <p style="text-align: center;">CAUTION</p> <p>Check that tracker swivel space is free of obstacles</p> <p>Press TRACKER TILT DOWN, until tracker is tilted down completely</p> <p>Press CLOSE ROOF until roof is closed</p> <p>Lock roof (right)</p> <p>Check that handle brake is secured</p> <p>Open flap to hydraulic pump equipment</p>	<p>Lock roof (left)</p> <p>Disconnect external station field wires (if required)</p> <p>Disconnect laser safety switch (if required)</p>

NO 1	NO 2
<p>Set flow control lever to COARSE</p> <p>Lower jacks with the three hand levers</p> <p>Press PUMP OFF</p> <p>Close the flap</p>	<p>Clean hydraulic jacks</p> <p>Disconnect refuelling device</p> <p>Assist No 3 in carrying OS to prime mover</p> <p>Close two flaps on fan filter unit</p>

NO 1	NO 2	NO 3
<p>Ensure FCU main switch is off "SWITCH OFF PSU"</p>	<p>Set operation switch on PSU to STANDBY</p> <p>Wait about two minutes</p> <p>Set operation switch to OFF</p> <p>Set BATTERY switch to 0</p>	<p style="text-align: center;">CAUTION</p> <p>The exhaust tube is very hot</p> <p>Wear heat protective mittens</p>

NO 1	NO 2	NO 3
Remove radio antenna	Update PSU logbook	Disconnect exhaust tube
Update FCU logbook	Roll down PSU tarpaulin	Allow tube to cool down
	Replace fire extinguisher	Store tube
<p style="text-align: center;">NOTE</p> <p>If the FCU is not used over a long period of time, it should be protected with the roof-mounted tarpaulin.</p>		

NO 1	NO 2	NO 3	NO 4	NO 5
Guide prime mover to towing hook	Lift towbar	Lift towbar	Back prime mover to FCU guided by No 1	
	Hook towbar into towing eye	Hook towbar into towing eye		
	Hook up yellow brake hose	Hook up red brake hose		
	Connect lighting cable			
Remove wheel chock				

NO 1	NO 2	NO 3	NO 4	NO 5
Release hand brake "MOUNT"				
FINAL CHECKS PRIOR TO MOVING:				
<ul style="list-style-type: none"> • Condition and pressure of tires • Hand brake unlocked • Towbar properly connected • Covers and flaps fitted correctly • Operation of lights and brakes • All equipment loaded and secured 				

CHAPTER 7 RANGE FIRING

1. This part deals with specific safety measures applicable when a Skyguard Section is deployed on a firing range. Unless otherwise mentioned, normal procedures apply. Deployment on a firing range involves additional personnel and equipment.
2. The Range Safety Officer (RSO) is responsible to the Officer in Charge (OIC) for the safe conduct of a Gun/Skyguard live firing practice. If more than one firing point (FP) is in use, a Firing Point Officer (FPO) is required for each FP. The FPO is responsible to the RSO for the safe conduct of practice firing.
3. No Skyguard or gun laser will be operated on the range without the proper laser attenuation filter installed. Filter values are 30 dB for the Skyguard and 20 dB for the gun. It is the RSO's responsibility to ensure these filters are in place prior to the commencement of practice firing.
4. Range Standing Orders and the manual on Range Training, B-GL-304-003/TS-001, are the authoritative references for conducting a range practice. Specific instructions for range safety are provided in these publications, including details concerning individual responsibilities of the RSO, FPO and other range personnel.

SECTION 1
SYSTEMATIC SEQUENCE FOR SKYGUARD SECTION
COMING INTO ACTION

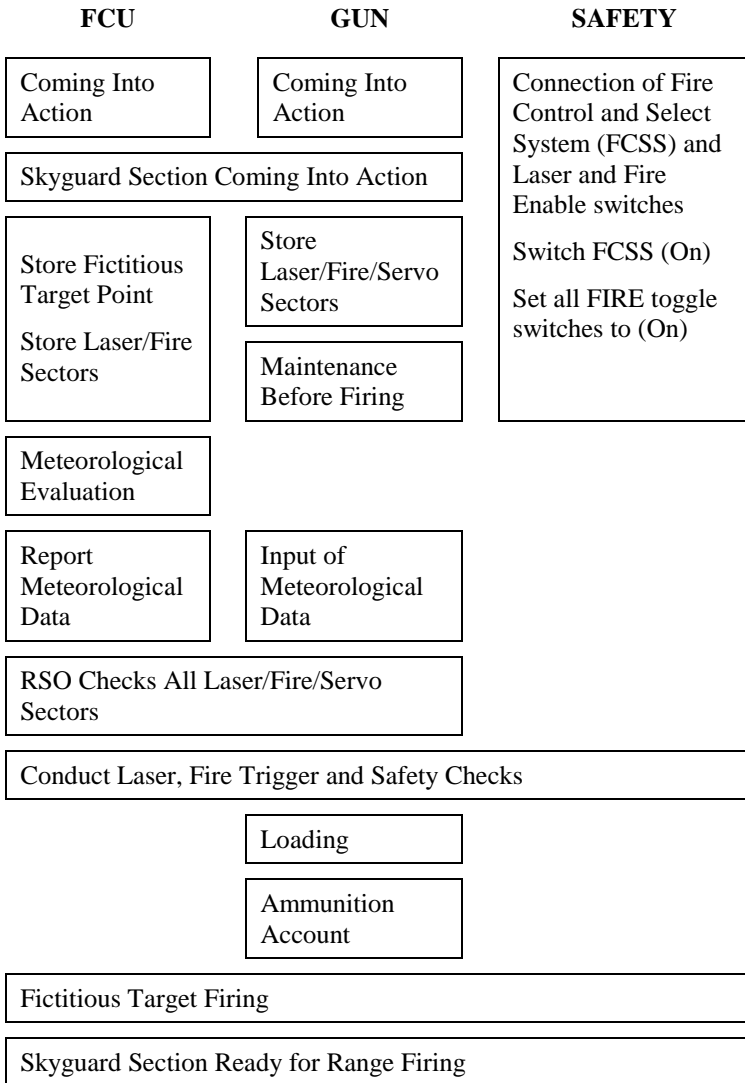

Figure 7-1: Systematic Sequence for Skyguard Section Coming Into Action

SECTION 2
DUTIES OF THE SKYGUARD SECTION COMMANDER

5. The Skyguard Section Commander will stop firing if:
 - a. the FPO or RSO orders "CHECK FIRING";
 - b. an aircraft (other than the towing aircraft) is reported in or near the range;
 - c. a vessel, on and/or enters an over-water range;
 - d. a target is damaged and has difficulty flying;
 - e. range safety communications fail; or
 - f. for any other reason it is deemed unsafe for firing to continue.

6. The laser rangefinder on the Skyguard will not be operated unless specific permission has been given by the RSO. Prior to operation, the laser interrupter (safety switch) must be hooked up by the Skyguard Section Commander, a Laser Safety Supervisor (LSS) must be available, and the warning lights on the Skyguard tracker upper mount must be turned on to warn personnel of the laser beam hazard.

BEFORE FIRING

7. The Skyguard Section Commander will ensure that the lamp LASER DISABLE is on or off, depending on the engagement mode, and that the fire sectors are marked on the Plan Position Indicator (PPI).

DURING FIRING

8. When firing in the Remote Mode, the Skyguard Section Commander will ensure:
 - a. that the target is visible on the TV monitor;

- b. that the correct target is being tracked; and
- c. that the target is only engaged once the order "FIRING RUN" has been received, indicating that the target is within the designated sectors marked on the PPI and visible on the TV monitor.

SECTION 3
DUTIES OF WEAPON SAFETY OFFICER/LASER SAFETY SUPERVISOR

9. The Skyguard Weapon Safety Officer (WSO) shall be a qualified Skyguard Detachment Commander appointed by the RSO. The Skyguard LSS shall be a qualified Skyguard Operator or Detachment Commander appointed by the RSO.

BEFORE FIRING

10. The WSO will ensure:
- a. That the appropriate safety sectors are marked on the PPI and that, if the Skyguard laser is not to be used, the lamp LASER DISABLE on the control panel monitor is on.
 - b. That if the Skyguard laser rangefinder is to be used, the lamp LASER DISABLE is off and the laser interrupter (safety switch) is connected and controlled by an LSS. The external warning lights must be operating prior to laser actuation.
 - c. That a 30 dB filter is installed on the Skyguard laser prior to firing.
 - d. That the laser sectors are marked designating left and right boundaries of the laser sectors.
11. The LSS will ensure:

- a. that the laser interrupter (safety switch) is properly connected and that external warning lights are operating; and
- b. under the direction of the WSO, that the appropriate laser sectors are marked.

DURING FIRING

12. The WSO will ensure:
 - a. that the target is visible on the TV monitor and that the correct target is being tracked; and
 - b. that a qualified LSS operates the Skyguard laser interrupter (safety switch) and only engages the interrupter when the target is within the designated laser sectors.

AFTER FIRING

13. The WSO will:
 - a. ensure that the lamp LASER DISABLE on the control panel monitor is on; and
 - b. report "SKYGUARD SAFE" to the FPO/RSO only when the laser has been disabled.
14. The LSS will ensure that the laser interrupter (safety switch) is removed and properly stored.

SECTION 4 RANGE SUPPORT EQUIPMENT

15. Range support equipment consists of:
 - a. FCSS;

Skyguard Drill Book

- b. Communication and Intercom System (CIS); and
- c. Video Evaluation System (VES).

FCSS

16. The FCSS gives the RSO the ability to ENABLE or DISABLE every laser or fire signal on the range. Activating the power switch will force "CHECK FIRING" for the whole range in a matter of seconds. Each laser or fire signal can also be handled individually.

17. The FCSS must be installed and connected by a qualified Range Equipment Operator (REO).

18. The fire enable switch and the laser enable switch are to be operated by the WSO and LSS, and are part of the FCSS.

CIS

19. The CIS gives the RSO all necessary communication links required to control the FP. Available communication links are:

- a. one way communication (listening) to all connected Skyguard Sections;
- b. two way communication between FCSS and selected FCUs and guns;
- c. loudspeaker for announcements to all personnel on the FP; and
- d. an override intercom station (voice request) for range safety.

20. The CIS is installed and connected by a qualified REO.

VES

21. The VES is used primarily to evaluate firing results of the gun and Skyguard operator performance against targets using live ammunition. A secondary role is to provide the RSO with real-time information about the target currently tracked by the Skyguard and guns. The RSO will only enable firing (using the FCSS) if the Skyguard and guns are tracking the correct target.

22. The VES is to be installed, connected and operated by a qualified REO.

SETTINGS FOR VES

NO 1	VES/CIS OPERATOR
<p>"SKYGUARD READY FOR VES SETTINGS"</p> <p>Select Menu 14/6— RECORDING</p> <p>Sensor selection, select Video Tracker (VT) data</p> <p>"VES SETTINGS DONE"</p>	<p>VES Operator requests CIS Operator to command FCU for VES setting</p> <p>"ATTENTION SKYGUARD, VIDEO EVALUATION SYSTEM SETTINGS, REPORT"</p> <p>VES Operator confirms to CIS Operator correct settings</p> <p>"VES SETTINGS FINISHED"</p>

SECTION 5
SAFETY SECTORS

23. Two types of sectors must be observed during range firing:

- a. the laser sector; and
- b. the fire sector.

LASER SECTOR

24. Use of the laser is permitted within the laser sector only. The laser sector is usually larger than the fire sector.

FIRE SECTOR

25. Firing is only permitted within the fire sector. The lamp READY TO FIRE indicates whether the projected point of impact is within the fire sector. It may be possible to fire even if the tellback symbol is outside the fire sector.

SET LASER SECTOR

26. Ensure laser safety profile is set to zero. Values are referenced to the keyed in north direction.

RSO	NO 1
"ATTENTION SKYGUARD, SET LASER SECTOR" "LEFT LIMIT...MILS" "RIGHT LIMIT...MILS"	"SET LASER SECTOR" Select Menu 5/5—LASER SECTORS (MANUALLY), "SKYGUARD READY TO SET LASER SECTOR" Left limit—enter value, "LEFT LIMIT SET"

RSO	NO 1
<p>"UPPER LIMIT...MILS"</p> <p>"LOWER LIMIT...MILS"</p>	<p>Right limit—enter value, "RIGHT LIMIT SET"</p> <p>Upper limit—enter value, "UPPER LIMIT SET"</p> <p>Lower limit—enter value, "LOWER LIMIT SET"</p> <p>Store Laser Sector 1—enter (YES), "LASER SECTOR SET"</p>

SET FIRE SECTOR

27. Values are referenced to the keyed in north direction.

RSO	NO 1
<p>"ATTENTION SKYGUARD, SET LASER SECTOR"</p> <p>"LEFT LIMIT...MILS"</p> <p>"RIGHT LIMIT...MILS"</p>	<p>"SET FIRE SECTOR"</p> <p>Select Menu 12/2/2—FIRE SECTORS (MANUALLY), "SKYGUARD READY TO SET FIRE SECTOR"</p> <p>Left limit—enter value, "LEFT LIMIT SET"</p>

RSO	NO 1
<p>"UPPER LIMIT...MILS"</p> <p>"LOWER LIMIT...MILS"</p>	<p>Right limit—enter value, "RIGHT LIMIT SET"</p> <p>Upper limit—enter value, "UPPER LIMIT SET"</p> <p>Lower limit—enter value, "LOWER LIMIT SET"</p> <p>Store Fire Sector—enter (YES), "FIRE SECTOR SET"</p>

CHECK LASER SECTOR

28. In case VES settings have already been fixed, restore sensor selection VT data when check is finished.

RSO	NO 1	NO 2
<p>"ATTENTION SKYGUARD, CHECK LASER SECTOR"</p>	<p>"CHECK LASER SECTOR"</p> <p>Select Menu 14/6— RECORDING</p> <p>Sensor selection, select coder</p>	

RSO	NO 1	NO 2
<p>Check limit with compass</p> <p>Check position of arc marker, "CHECK RIGHT LIMIT"</p> <p>Check limit with compass</p> <p>Check position of arc marker, "CHECK UPPER LIMIT"</p>	<p>Select Menu 5/5/3—LASER SECTOR (MANUALLY)</p> <p>Inform RSO "TRACKER ON LEFT LIMIT"</p> <p>Inform RSO, "TRACKER ON RIGHT LIMIT"</p>	<p>Move tracker to left limit</p> <p>Move tracker to right limit</p> <p>Move tracker to upper limit</p>

RSO	NO 1	NO 2
<p>Check limit visually, "CHECK LOWER LIMIT"</p> <p>Check limit visually, "LASER SECTOR CHECK FINISHED"</p>	<p>Inform RSO, "TRACKER ON UPPER LIMIT"</p> <p>Inform RSO, "TRACKER ON LOWER LIMIT"</p>	<p>Move tracker to lower limit</p>

CHECK FIRE SECTOR

29. In case VES settings have already been fixed, restore sensor selection VT data when check is finished.

RSO	NO 1	NO 2
<p>"ATTENTION SKYGUARD, CHECK FIRE SECTOR"</p>	<p>"CHECK FIRE SECTOR"</p> <p>Select Menu 14/6— RECORDING</p>	

RSO	NO 1	NO 2
<p data-bbox="213 716 426 800">Check limit with compass, "CHECK RIGHT LIMIT"</p> <p data-bbox="213 1057 426 1141">Check limit with compass, "CHECK UPPER LIMIT"</p>	<p data-bbox="469 253 653 306">Sensor selection, select coder</p> <p data-bbox="469 347 642 461">Select Menu 12/12/2—SITE DATA (MANUALLY)</p> <p data-bbox="469 594 653 678">Inform RSO, "TRACKER ON LEFT LIMIT"</p> <p data-bbox="469 935 653 1019">Inform RSO, "TRACKER ON RIGHT LIMIT"</p> <p data-bbox="469 1276 653 1360">Inform RSO, "TRACKER ON UPPER LIMIT"</p>	<p data-bbox="723 500 939 553">Move tracker to left limit</p> <p data-bbox="723 842 896 896">Move tracker to right limit</p> <p data-bbox="723 1183 896 1237">Move tracker to upper limit</p>

RSO	NO 1	NO 2
<p>Check limit visually, "CHECK LOWER LIMIT"</p> <p>Check limit visually, "FIRE SECTOR CHECK FINISHED"</p>	<p>Inform RSO, "TRACKER ON LOWER LIMIT"</p>	<p>Move tracker to lower limit</p>

**SECTION 6
SKYGUARD LASER/SAFETY CHECK**

30. The laser check tests the operation of the laser circuit after safety devices have been installed. The laser check must be carried out before firing commences, and is ordered by the RSO. Prior to this check, all lasers must have their respective filters (Gun 20 dB, Skyguard 30 dB) installed.

NO 1	FCSS OPERATOR	LSS
<p>"SKYGUARD LASER CHECK"</p>	<p>"ATTENTION SKYGUARD, LASER CHECK, REPORT"</p>	

NO 1	FCSS OPERATOR	LSS
<p>Ensure toggle switch WARNING LASER on power distribution upper mount is at position ON</p> <p>Restore Skyguard operational mode</p> <p>Ensure toggle switch LASER on main distribution is at position ON</p> <p>Press LASER DISABLE (lamp off)</p> <p>"SKYGUARD READY FOR LASER CHECK"</p>	<p>Set LASER selector to ON</p> <p>Announce via loudspeaker</p> <p>"ATTENTION SKYGUARD LSS LASER CHECK"</p>	<p>Enable laser enable switch</p> <p>Observe warning lights on tracker</p>

NO 1	FCSS OPERATOR	LSS
	<p>"SKYGUARD LASER/SAFETY CHECK FINISHED"</p> <p>Announce via loudspeaker, "SKYGUARD LASER/SAFETY CHECK FINISHED"</p>	<p>Release laser enable switch</p>

**SECTION 7
GUN LASER/SAFETY CHECK**

NO 1	GUN OPERATOR	FCSS OPERATOR	LSS
<p>"SKYGUARD SECTION READY FOR LASER CHECK"</p>		<p>"ATTENTION SKYGUARD SECTION, LASER CHECK, LASER SECTORS ARE ENABLED, REPORT"</p> <p>Set LASER selectors to ON</p> <p>Announce via loudspeaker, "ATTENTION WSO, LASER CHECK"</p>	

NO 1	GUN OPERATOR	FCSS OPERATOR	LSS
<p>"SKYGUARD SECTION SAFETY CHECK"</p> <p>Advise FCSS Operator of result of safety check</p> <p>"LASER AND SAFETY CHECKS FINISHED"</p>	<p>"GUN 1(2) SAFETY CHECK"</p> <p>Carry out check</p> <p>Report to Skyguard "GUN 1(2) LASER NOT OK (OK)"</p>	<p>Announce via loudspeaker, "SAFETY CHECK"</p> <p>If safety check was OK, "LASER AND SAFETY CHECK FINISHED"</p>	

NO 1	GUN OPERATOR	FCSS OPERATOR	LSS
	<p>"GUN 1(2) LASER AND SAFETY CHECK FINISHED"</p> <p>Move guns to standby direction</p>	<p>Announce via loudspeaker "LASER AND SAFETY CHECK FINISHED"</p>	<p>Release laser enable switch</p>

**SECTION 8
FIRE TRIGGER/SAFETY CHECK**

NO 1	GUN OPERATOR	FCSS OPERATOR	WSO/LSS
<p>"SKYGUARD SECTION READY FOR FIRE TRIGGER CHECK"</p>		<p>"ATTENTION SKYGUARD SECTION, FIRE TRIGGER CHECK, FIRE SECTORS ARE ENABLED, REPORT"</p> <p>Set FIRE selectors to ON</p>	

NO 1	GUN OPERATOR	FCSS OPERATOR	WSO/LSS
<p>"ATTENTION FIRE TRIGGER CHECK"</p> <p>Select Menu 14/2— FICTITIOUS TARGET FIRING WITH GUNS</p> <p>Press ALARM GUN once</p> <p>"ATTENTION 3, 2, 1, FIRE"</p>	<p>"GUN 1(2) FIRE TRIGGER CHECK"</p> <p>Prepare for check</p> <p>"GUN 1(2) READY"</p> <p>Switch to REMOTE</p>	<p>Announce via loudspeaker, "ATTENTION WSO, FIRE TRIGGER CHECK"</p>	<p>After gun moves into fire sectors, press fire enable switch</p>

NO 1	GUN OPERATOR	FCSS OPERATOR	WSO/LSS
<p>Press READY TO FIRE</p> <p>Press ALARM GUN twice</p> <p>Advise FCSS Operator of result of fire trigger check</p>	<p>"GUN 1(2) TRIGGER OK (NOT OK)"</p> <p>Switch to LOCAL</p>	<p>If fire trigger check was OK, set toggle switches FIRE to OFF</p> <p>"SAFETY CHECK, FIRE SELECTORS ARE DISABLED"</p> <p>Announce via loudspeaker, "SAFETY CHECK"</p>	<p>When alarm tone sounds twice, release trigger interrupter</p>

NO 1	GUN OPERATOR	FCSS OPERATOR	WSO/LSS
<p>"SKYGUARD SECTION SAFETY CHECK"</p> <p>Press ALARM GUN once</p>	<p>"GUN 1(2) SAFETY CHECK"</p> <p>Switch to REMOTE</p>		<p>After gun moves into fire sectors, press fire interrupter</p>
<p>"SAFETY CHECK 3, 2, 1, FIRE"</p> <p>Press READY TO FIRE</p> <p>Press ALARM GUN twice</p> <p>Advise FCSS Operator of result of safety check</p>	<p>"GUN 1(2) TRIGGER NOT OK (OK)"</p> <p>Switch to LOCAL</p>		<p>When alarm tone sounds twice, release trigger interrupter</p>

NO 1	GUN OPERATOR	FCSS OPERATOR	WSO/LSS
<p>"FIRE TRIGGER AND SAFETY CHECKS FINISHED"</p>	<p>"GUN 1(2) FIRE TRIGGER AND SAFETY CHECKS FINISHED"</p>	<p>If safety check was OK, "FIRE TRIGGER AND SAFETY CHECKS FINISHED"</p> <p>Announce via loudspeaker, "FIRE TRIGGER AND SAFETY CHECKS FINISHED"</p>	

**SECTION 9
FIRING AT TOWED TARGETS**

31. During firing in Remote Mode, the Skyguard Section Commander will ensure that the target is visible on the television (TV) monitor and that the correct target is being tracked. At that point, the commander reports "TRACKING SLEEVE" to the RSO. The TV Operator must watch the TV monitor at all times and make sure that the FCU is tracking the sleeve and not the towing aircraft.

32. TV Operator reports "TRACKING SLEEVE" to Skyguard Section Commander.

33. If lock-on to the towing aircraft should occur, the TV Operator must report "CHECK FIRE, TRACKING AIRCRAFT" to the Skyguard Section Commander. Press button (DESIGN/NEXT/RESET) to interrupt tracking.

34. **Misfire Drills:**

- a. Fire the weapons. If weapons fail to fire, No 2 repress "READY TO FIRE" button.
- b. If weapons still do not fire, hand over the engagement to Guns—"GUN 1 (2) TAKE OVER".
- c. After the engagement or when time permits, No 1 requests readiness checks be redone on the guns and executes the following:
 - (1) No 3 checks data connections.
 - (2) No 1 performs data transmission check. Follow procedures as per section 4.1.
 - (3) No 1 performs fictitious target firing. Follow procedures as per section 4.6.
 - (4) No 1 performs functional check. Select Menu 3/3/7/1 and follow instructions on Plasma Display Monitor.

CHAPTER 8

DETERMINE BALLISTIC DATA AND RANGES

1. The computer calculates gun firing angles based on the following external ballistic conditions:
 - a. Atmospheric Pressure—1013 mbar;
 - b. Air Temperature—+15°C;
 - c. Relative Humidity—65%;
 - d. Wind Speed—0 m/s; and
 - e. Muzzle Velocity (MV)—1175 m/s.

2. A deviation from these nominal values affects trajectories as follows:
 - a. **Lower Air Pressure.** Smaller density = extended trajectory.
 - b. **Higher Air Temperature.** Smaller density = extended trajectory.
 - c. **Higher Humidity.** Smaller density = extended trajectory.
 - d. **Wind.** Wind always deflects a projectile in the wind direction, wind strength determining the amount of deviation.
 - e. **Lower MV.** Reduced trajectory

3. For correct calculation of firing angles, it is necessary to determine actual values and input them into the computer.

ATMOSPHERIC PRESSURE

4. Read off the pocket barometer and note the value. The colour indicated in the small window determines the colour of the valid scale.

AIR TEMPERATURE

5. Whirl the sling thermometer for about one minute. Read off the indicated value and note it.

HUMIDITY

6. Relative humidity is a function of altitude and differs widely. Experience has shown that a mean value of 65% can be used which must only be corrected under extreme conditions. Typically on a rainy day, 90% would be set, whereas on a cold, dry winter day, 35% would be selected.

WIND SPEED AND DIRECTION

7. Wind speed and direction are determined by means of tracking a gas filled balloon fitted with a reflector. The balloon is followed with the Optical Sight (OS) until the tracker locks on. As long as the tracker is not tracking, the operator is notified by the blinking mode message **NOT TRACKING** on the television (TV) monitor.

8. After the tracker has locked on, the mode message to the operator will change to **TRACKING**. During tracking, the actual height, distance, direction and speed of the balloon will be displayed continuously.

9. Seven wind layers are measured. The actual wind speed and wind direction for each layer will be displayed as soon as the balloon has completely passed through a layer. At the same time, values for ballistic wind speed and wind direction will also be computed.

10. If the tracker loses the balloon, the operator will be notified by the fast blinking mode message **BALLOON LOST**. In this case,

balloon tracking should be stopped and the operator should again try to lock the tracker onto the balloon. If it is not possible to lock on throughout a layer, the wind speed and wind direction for this layer will be computed based on the information the program received until the balloon was lost.

Lamp DESIGNATION AUTO OFF: On

Lamp SHORT PULSE: On

NO 1	NO 2	NO 3
<p>"ATTENTION BALLOON TRACKING"</p> <p>Select Menu 14/1— BALLOON TRACKING</p> <p>"3, 2, 1, RELEASE"</p> <p>Tracking start, enter (Yes)</p>	<p>Tracking is indicated on the TV monitor</p>	<p>"BALLOON TRACKING"</p> <p>Release balloon and report "BALLOON START"</p> <p>Track balloon with collimator</p> <p>At approximately 300 m press on target push button until signal tone starts</p>

NO 1	NO 2	NO 3
When the balloon has reached the corresponding height, stop, enter (Yes) "BALLOON TRACKING FINISHED"	"TRACKING BALLOON" Watch tracking	"BALLOON TRACKING FINISHED"

INITIAL MV CALCULATION

11. The nominal MV value for 35 mm ammunition is as follows:

- a. HEI—1175 m/s;
- b. TP—1175 m/s; and
- c. AHEAD—1050 m/s.

12. The actual MV value deviates from the nominal value according to:

- a. increasing number of rounds being fired through the barrels (called barrel stress), which is noted in the logbook of each gun; and
- b. variations in powder temperature (taken as ambient surface air temperature).

13. The actual MV value resulting from the variation of barrel stress MV_{bs} and powder temperature ΔMV_{pt} is calculated using the following formula:

$MV = MV_{bs} + \Delta MV_{pt}$

MV_{bs} and ΔMV_{pt} are obtained using the appropriate tables (see Figures 8-1 and 8-2)

14. Example:

Barrel Stress: 600 (rounds fired), → $MV_{bs} = 1165 \text{ m/s}$
ammunition type HEI

Powder Temperature: 30°C, ammunition → $\Delta MV_{pt} = +4.5 \text{ m/s}$
type HEI

$$\underline{MV = 1165 \text{ m/s} + 4.5 \text{ m/s} = 1169.5 \text{ m/s}}$$

15. For a gun, MV is calculated as the average of the MVs for the individual barrels.

NO OF ROUNDS	MV _{bs}	NO OF ROUNDS	MV _{bs}	NO OF ROUNDS	MV _{bs}	NO OF ROUNDS	MV _{bs}	NO OF ROUNDS	MV _{bs}	NO OF ROUNDS	MV _{bs}
0	1175.0	1800	1152.5	5600	1142.5	7600	1131	9400	1110		
100	1173	1900	1152	5700	1142	7700	1130	9500	1108.5		
200	1171	2000	1151.5	5800	1141.5	7800	1129.5	9600	1107		
300	1169	2100	1151	6000	1141	7900	1128.5	9700	1105.5		
400	1168	2200	1150.5	6100	1140.5	8000	1127.5	9800	1104		
500	1166.5	2300	1149.5	6300	1139.5	8100	1126.5	9900	1102		
600	1165	2400	1149	6400	1139	8200	1125.5	10000	1100.5		
700	1163.5	2600	1148.5	6500	1138.5	8300	1124.5				
800	1162.5	2700	1148	6600	1138	8400	1123				
900	1161	2900	1147.5	6700	1137.5	8500	1122.5				
1000	1160	3000	1147	6800	1137	8600	1121				
1100	1159	3300	1146.5	6900	1136.5	8700	1119.5				
1200	1158	3400	1146	7000	1136	8800	1118.5				
1300	1157	3600	1145.5	7100	1135	8900	1117				
1400	1156	3800	1145	7200	1134.5	9000	1116				
1500	1155	4200	1144	7300	1133.5	9100	1114.5				
1600	1154	5200	1143.5	7400	1133	9200	1113				
1700	1153	5300	1143	7500	1132	9300	1111.5				

Figure 8-1: MV According to Barrel Stress MV_{bs} for HEI and TP Ammunition

Powder Temperature (T) in °C
MV Deviation (ΔMV_{pt}) in m/s

T	ΔMV_{pt}	T	ΔMV_{pt}	T	ΔMV_{pt}	T	ΔMV_{pt}	T	ΔMV_{pt}	T	ΔMV_{pt}	T	ΔMV_{pt}	T	ΔMV_{pt}
-40	-16.5	-23	-11.4	-6	-6.3	11	-1.2	28	3.9	45	9.0				
-39	-16.2	-22	-11.1	-5	-6.0	12	-0.9	29	4.2	46	9.3				
-38	-15.9	-21	-10.8	-4	-5.7	13	-0.6	30	4.5	47	9.6				
-37	-15.6	-20	-10.5	-3	-5.4	14	-0.3	31	4.8	48	9.9				
-36	-15.3	-19	-10.2	-2	-5.1	15	0	32	5.1	49	10.2				
-35	-15.0	-18	-9.9	-1	-4.8	16	0.3	33	5.4	50	10.5				
-34	-14.7	-17	-9.6	0	-4.5	17	0.6	34	5.7						
-33	-14.4	-16	-9.3	1	-4.2	18	0.9	35	6.0						
-32	-14.1	-15	-9.0	2	-3.9	19	1.2	36	6.3						
-31	-13.8	-14	-8.7	3	-3.6	20	1.5	37	6.6						
-30	-13.5	-13	-8.4	4	-3.3	21	1.8	38	6.9						
-29	-13.2	-12	-8.1	5	-3.0	22	2.1	39	7.2						
-28	-12.9	-11	-7.8	6	-2.7	23	2.4	40	7.5						
-27	-12.6	-10	-7.5	7	-2.4	24	2.7	41	7.8						
-26	-12.3	-9	-7.2	8	-2.1	25	3.0	42	8.1						
-25	-12.0	-8	-6.8	9	-1.8	26	3.3	43	8.4						
-24	-11.7	-7	-6.6	10	-1.5	27	3.6	44	8.7						

Figure 8-2: MV Deviation According to Powder Temperature ΔMV_{pt} (AHEAD), HEI and TP)

RANGE DETERMINATION TO REFERENCE POINT BY MEANS OF RADAR

16. The reference point should be clearly visible without reflecting background. Roughly estimate the range to the reference point.

PRESETTINGS IN THE FIRE CONTROL UNIT (FCU)	
Menu 5/3	Moving Target Indication (MTI) Mode— Select (MTI Off)
Menu 14/6	Sensor Selection—Select (KA Radar = RKa Data)
Menu 14/6	Tracker Command On—Enter (No)
Pushbutton RADAR SILENCE X	Press (Lamp On)
PROCEDURE	
Sight on reference point by means of joystick	
Set toggle switch AZIMUTH DRIVE on main distributor to position OFF	
Lock on reference point by pushbutton SECTOR SEARCH KA	
Verify that target indication on range trace is clearly visible in the centre	
Read range display on text line 19 of the TV monitor	
Re-establish normal settings	

RANGE DETERMINATION TO REFERENCE POINT BY MEANS OF LASER

17. Preparation:
 - a. The reference point should be clearly visible without reflecting background.
 - b. Select an existing reference point at a distance 800 to 3000 metres from the Skyguard or set up the retro-reflector CF HAA 020 AA.
 - c. Roughly estimate the range to the reference point.
 - d. Mount the filter to the laser transceiver on the Skyguard, 50 dB for retro-reflector, 30 dB for other reference points.
 - e. Connect the laser safety switch to the OS connector panel.

DANGER

This method should only be used if range determination is not possible by other means. Strictly observe stated safety rules when following this procedure.

PRESETTINGS IN THE FCU	
Menu 14/6	Sensor Selection—Select (Laser)
Menu 14/6	Tracker Command On—Enter (NO)
Menu 5/1	Track While Scan (TWS) Track Initialisation—Select (Manual)
Menu 5/1	Plan Position Indicator (PPI) Range—Select (10 km)

PRESETTINGS IN THE FCU	
Menu 5/2	MTI Mode—Select (MTI Off)
Return to tactical menu	Press (EXIT)
Pushbutton DESIGNATION AUTO OFF	Press (Lamp On)
Pushbutton RADAR SILENCE X	Press (Lamp On)
PROCEDURE	
<p>Precisely sight on retro-reflector or reference point by means of joystick</p> <p>Set toggle switch AZIMUTH DRIVE on main distributor to position OFF</p> <p>Switch on laser (safety off)</p> <p>Press MOST THREAT TARGET continuously and position tracking ball mark to the estimated range of the reference point (range displayed on the Plasma Display Monitor (PDM))</p> <p>Press DESIGN NEXT/RESET to lock on reference point</p> <p>Release MOST THREAT TARGET</p> <p>Read range on lower part of TV display and on the PDM</p> <p>Return all switches to nominal settings</p>	

CHAPTER 9 OPERATION WITH DEGRADED EQUIPMENT

1. The procedures in this part show which operations are possible with degraded equipment due to Power Supply Unit (PSU) or hydraulic group failure.

START THE PSU WITH EXTERNAL BATTERY

2. If internal batteries are drained, discharged or damaged, the operator can start the PSU with a connection to another 24 V battery or to a vehicle with 24 V supply:
 - a. Connect 24 V external starter cable to the external battery connection of the PSU.
 - b. Set battery switch to I.
 - c. Start the PSU as per operating instruction.
 - d. Disconnect the external starter cable from the PSU.

START THE PSU IN CASE OF EMERGENCY

CAUTION

This operating mode can damage or destroy the PSU and must only be used in acute emergencies.

3. To start the PSU in an emergency:
 - a. Turn battery switch to I.
 - b. Set GEN toggle switch to ON.
 - c. Depress the mechanical lock on the operation switch.

- d. Turn operation switch to EMERGENCY OPERATION (E appears on the display).
 - e. Actuate toggle switch START.
4. The engine immediately runs at 4000 rpm (even though the engine temperature is well below operating temperature).

NOTE

In emergency operation mode, the monitoring logic is deactivated. Faults are therefore neither detected nor displayed.

OPERATE THE HYDRAULIC GROUP MANUALLY

5. To provide access to the hand pump:
- a. Place the PSU tilting support into the horizontal position.
 - b. Remove the two fuel cans.
 - c. Unlock the two quick-release latches and fold up the rear panel.
 - d. Insert the hand pump lever into the hand pump.

EXTEND/RETRACT HYDRAULIC JACKS AND COARSE LEVELLING

6. To extend or retract hydraulic jacks and coarse levelling:
- a. Open the flap to the hydraulic pump equipment.
 - b. Set flow control lever to COARSE.
 - c. Lock the three hand levers in the appropriate positions (RAISE or LOWER).

- d. Order manual pumping.
- e. Check that all three jacks extend/retract.
- f. Level the Fire Control Unit (FCU) coarsely.
- g. Close the flap to the hydraulic pump equipment.

OPEN/CLOSE THE ROOF

7. The safety circuit does not operate in the event of a power failure. Ensure the following before opening or closing the roof:

- a. Tracker in zero position.
 - b. Both covers of the electronics cabinet must be closed.
 - c. The tracker must be tilted up and locked or completely tilted down.
 - d. Towbar in horizontal position.
 - e. No personnel on the roof.
8. After these conditions have been checked:
- a. Remove the cover on the switch-on panel by unlocking the four quick-release latches.
 - b. Manually actuate the appropriate valves.
 - c. Order manual pumping.

TILT UP/DOWN THE TRACKER

9. The safety circuits do not operate in the event of a power failure. Ensure the following before tilting the tracker up or down:

Skyguard Drill Book

- a. Operators seated in transport position.
 - b. Gooseneck microphone in transport position.
 - c. Folding table in transport position.
 - d. Roof completely open.
 - e. Tilt axis of tracker unlocked (if tilted up).
 - f. Search radar antenna locked.
 - g. Tracker elevation drive locked.
 - h. Tracker azimuth drive locked.
10. After these conditions have been checked:
- a. Remove the cover on the switch-on panel by unlocking the four quick-release latches.
 - b. Manually actuate the appropriate valves.
 - c. Order manual pumping.

MANUAL FINE LEVELLING

11. In the case of an automatic levelling malfunction, use the bubble level on the tracker upper mount for fine levelling of the FCU. A second operator is needed to actuate the appropriate valves. In this case, levelling accuracy must be checked frequently. Leave the service switch **LEVELLING** at **OFF**.

WEAPON ORIENTATION WITH REFERENCE OPTICS

12. In the event of an Electro-Optical Group (EOG) failure, the reference optics may be used for weapon orientation.

NO 1	NO 2	GUN OPERATOR
<p>Turn the safety switch to the position MAN ON ROOF and lock it</p> <p>Perform the procedure described in Section 4.3.1 (Direct Orientation)</p> <p>After orientation, turn the safety switch to position OPERATION</p>	<p>Climb onto the roof and install reference optics</p> <p>Adjust reference optics focus</p> <p>Move the tracker by hand while sighting on the weapon</p> <p>"GUN 1(2) SIGHTED ON"</p> <p>After orientation, remove reference optics</p>	<p>Perform the procedure described in Section 4.3.1 (Direct Orientation)</p>
<p style="text-align: center;">NOTE</p> <p>When sighting on a point nearer than 200 m, take into account the parallax between the television (TV) camera optics and the reference optics (up 27 cm, left 10 cm).</p>		

ORIENTATION OF OPTICAL SIGHT (OS) WITH REFERENCE OPTICS

NO 1	NO 2	GUN OPERATOR
<p>Switch the safety switch to the position MAN ON ROOF and lock it</p> <p>Perform the procedure described in Section 3.13 (Orientation of OS)</p> <p>After orientation, switch safety switch to position OPERATION</p>	<p>Climb onto the roof and install reference optics</p> <p>Adjust reference optics focus</p> <p>Move the tracker by hand while sighting on the OS</p> <p>"CHECKPOINT (OS) SIGHTED ON"</p> <p>After orientation, remove reference optics</p>	<p>Perform the procedure described in Section 3.17 (Orientation of OS)</p>

CHAPTER 10 MAINTENANCE AND CARE

1. This part contains "how to" procedures for operator preventive and corrective maintenance tasks, and faultfinding/troubleshooting.

SECTION 1 SPECIAL SAFETY PRECAUTIONS

2. Special safety precautions are not required.

SECTION 2 SUPPLIES AND LUBRICANTS

FUEL

3. Diesel fuel, DIN 51601, is used to operate the Power Supply Unit (PSU). At low temperatures, the flow characteristics of diesel fuel deteriorate to waxing. This can affect engine operation when using summer diesel. For this reason, winter diesel fuel, which works satisfactorily down to approximately -15°C (5°F), must be used in the cold season. At extremely low temperatures, regular gasoline should be mixed with diesel as per the table provided on the next page.

WARNING

As the mixture of diesel and gasoline reduces engine power, **only the absolutely necessary amount of gasoline** should be used (maximum 30%). Such a mixture is highly volatile and must be handled with care.

4. To ensure that the two types of fuel are well mixed, first add the necessary amount of gasoline then top up with diesel fuel.
5. The following chart provides winter fuel mixtures:

TEMPERATURE	SUMMER DIESEL	GASOLINE	WINTER DIESEL	GASOLINE
0 to -5°C (32 to 23°F)	85%	15%	100%	---
-5 to 15°C (23 to 5°F)	70%	30%	100%	---
-15 to -40°C (5 to -40°F)	---	---	70%	30%

ENGINE OIL

6. Diesel engines with exhaust turbochargers require engine oil of very high quality. Engine oil used in VW diesel engines with exhaust turbochargers must correspond to VW standard 505 00. Oils that conform to this standard are provided in the table below. Crankcase capacity is five litres.

BRAND	TYPE(S)	BRAND	TYPE(S)
AGIP	Sigma Turbo	ESSO	Diesel Motor Oil EGL 1800
ARAL	Super Elastic Turbo D	MOBIL	Super Diesel TD
AVIA	Multigrade HDC Plus	SHELL	Super Diesel T, Myrina Oil
BP	Strato, Visco Diesel, Vanellus C3 Extra	TEXACO	Dieseltex T

BRAND	TYPE(S)	BRAND	TYPE(S)
CASTROL	C 888, GTX 2 Turbo Tested	TOTAL	Rubia TIR
CHEVRON	Delo 450 Motor Oil Multigrade	VALVOLINE	Super HDS LD
ELF	Multiperformance 4 D, Presti Diesel SAE 15 W-40	VEEDOL	TD

7. Should these engine oils not be available, "CD" engine oil can be used **for topping up** as an emergency measure.

8. The viscosity of engine oils suitable for use at various temperature ranges is shown in Figure 10-1.

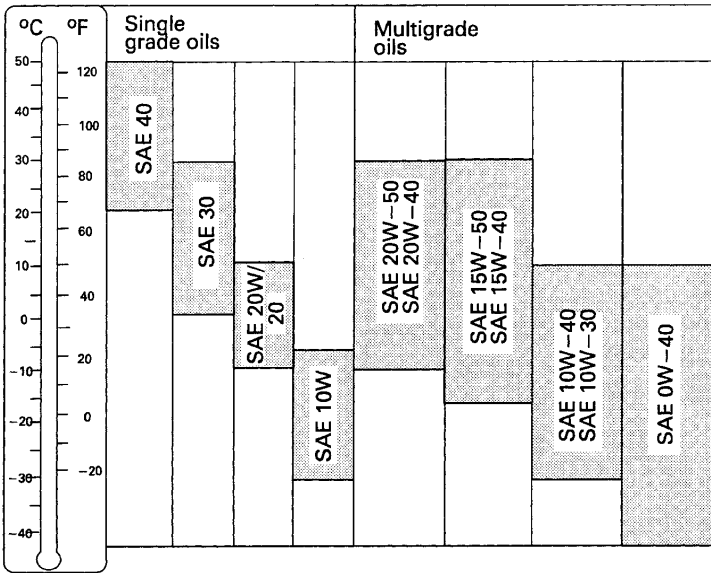

Figure 10-1: Engine Oil Viscosities

**SECTION 3
OPERATIONAL SUPPLIES AND MATERIALS**

FUELS AND LUBRICANTS

NUMBER	DESIGNATION	ITEM NUMBER	QUANTITY	NSN
1	Diesel Fuel	DIN 51 601	In litres	
2	Engine Oil— SAE 15W/40	C 2747 086-G	1.0 L	
3	Engine Oil— SAE 10W/30	C 2747 093	1.0 L	
4	Distilled Water	C 2704 511 B	1.0 L	
5	Grease Anti- Acid	C 2754 290	1.0 Kg	
6	Antifreeze Agent	C 2727 081	6.0 L	

APPLICATION OF FUELS AND LUBRICANTS

DESIGNATION	APPLICATION
Engine Oil	Diesel Engine/Top Up
Engine Oil	Control Lever Joints of Governor/Lubricate
Distilled Water	Battery Electrolyte Level/Top Up
Grease Anti–Acid	Battery Terminals/Grease
Antifreeze Agent	Cooling System/Antifreeze

**SECTION 4
MISCELLANEOUS SUPPLIES AND MATERIALS**

NUMBER	DESIGNATION	ITEM NUMBER	QUANTITY	NSN
1	Wiping Rag	C 6120 196	1.0 kg	---
2	Isopropyl Alcohol	C 2718 716	in litres	---

**SECTION 5
SPECIAL TOOLS AND TEST EQUIPMENT**

NUMBER	DESIGNATION	ITEM NUMBER	FIGURE NUMBER	NSN
1	Cap Extractor	CV FDA 050	10-8	5120-12-187-7683
2	Special Wrench	CU 301 277 DX	10-15/2	5120-12-131-6166
3	Lamp Extractor	CU 405 433-R	10-15/4	5120-12-185-7860

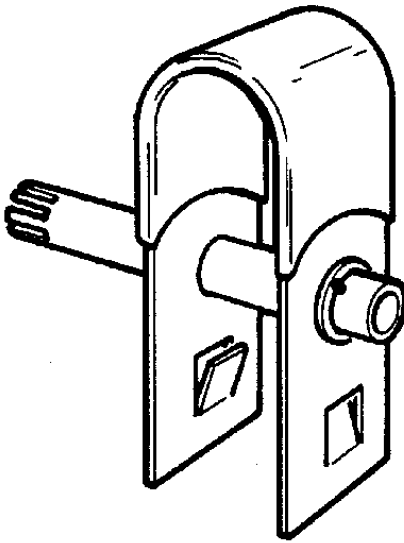

CV FDA 050

Figure 10-2: Cap Extractor

SECTION 6 PREVENTIVE MAINTENANCE TASKS

NOTE

All requisite preventive maintenance tasks to be performed by the operator and the maintainer are listed in the Preventive Maintenance Schedule (PMS) (refer to C-79-173-000/NY-001). The PMS outlines tasks and prescribes when and who must do the work. To carry out some of the more complex tasks, special instructions are necessary. For the maintainer, these instructions are contained in maintenance and repair manuals. Instructions for operator tasks are contained in this section.

CHECK HYDRAULIC FLUID LEVEL

9. Open the side flap located above the hydraulic pump equipment.

10. Bring the Fire Control Unit (FCU) into transport position on level ground.
11. Pull out the dipstick and read off the oil level.
12. The oil level must lie between the two marks on the dipstick. If this is not the case, call the maintainer to refill the hydraulic fluid.

CHECK ENGINE OIL LEVEL (SEE FIGURE 10-3)

13. The oil level can only be measured accurately if the PSU is in a horizontal position. Do not check the oil level immediately after switching off the engine. Allow time for the oil circulating in the engine to flow back into the crankcase. To measure the oil level, pull out the oil dipstick (2) and wipe it off with a clean cloth. Completely reinsert the oil dipstick up to the hilt, pull it out and read the oil level. The oil level indicated should be between the two markings MAX and MIN engraved on the oil dipstick. The oil level should never drop below the MIN mark. If the PSU must run for 10 to 12 hours, the oil level must be at least half way between the two markings. The difference between the MAX and MIN marks is 1 litre.

14. Procedure for refilling the engine with engine oil:
 - a. Unscrew cap (1).
 - b. Refill with engine oil (see Figures 10-2 and 10-3).
 - c. Check oil level with oil dipstick (2). The oil in the engine must not exceed the MAX mark.
 - d. Tightly screw back the cap.

EMPTY DUST COLLECTOR RESERVOIR ON AIR FILTER (SEE FIGURE 10-4)

15. To empty the dust collector reservoir on the air filter:
 - a. Unlock both clamps (2) and remove dust collector reservoir (1).

- b. Remove dust collector reservoir cover and empty reservoir.
- c. Mount cover on dust collector reservoir.
- d. Position dust collector on filter housing and lock both clamps.

NOTE

Verify that the label TOP faces upwards.

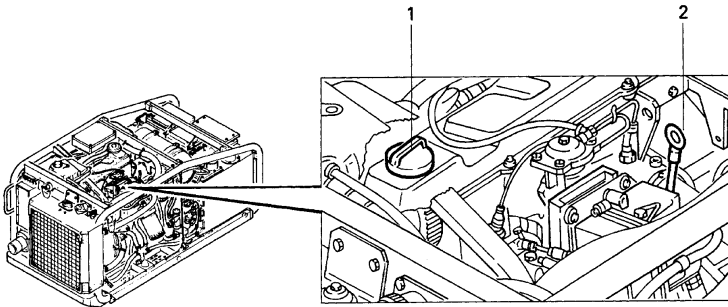

- 1 Cap
- 2 Oil Dipstick

Figure 10-3: Engine Oil Cap and Dipstick

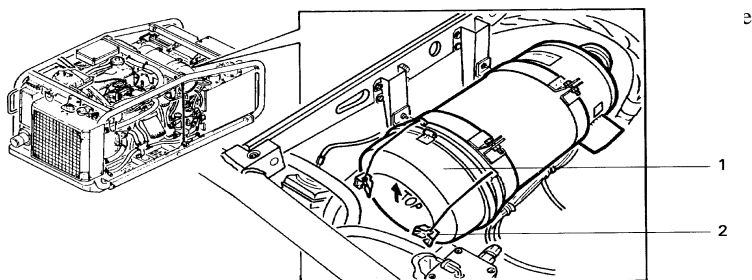

- 1 Dust Collector Reservoir
- 2 Clamps

Figure 10-4: Dust Collector Reservoir

DRAIN FUEL FILTER AND WATER SEPARATOR (SEE FIGURE 10-5)

16. To drain the fuel filter and the water separator:
 - a. Loosen vent screw (1) four turns.
 - b. Loosen drain plug (3) and drain off about 100 cm³ (0.1 L) of fuel (use a suitable container).
 - c. Tighten drain plug.
 - d. Check sealing ring of vent screw for damage and replace if necessary.
 - e. Tighten vent screw.
 - f. Repeat same procedure for fuel filter (4).

CLEAN AND LUBRICATE BATTERY TERMINALS

17. Clean and lightly lubricate battery terminals with anti-acid grease. Carefully check the external appearance of the batteries for raised plates, and damaged or torn housing.

CHECK COOLANT LEVEL (SEE FIGURE 10-6)

18. The coolant level must be slightly above the MINIMUM mark on the receptacle (1) when the engine is cold.

CHECK BATTERY ELECTROLYTE LEVEL AND REFILL IF NECESSARY

19. Prescribed acid level—5 mm above the top edge of the plates or to the acid level mark.

CAUTION

1. Only chemically pure, distilled water must be used to top up batteries.
2. Battery fluid is highly corrosive. Do not lay metal objects on the batteries.
3. Keep naked flames well away from batteries.
4. Smoking is forbidden in the vicinity of the batteries.

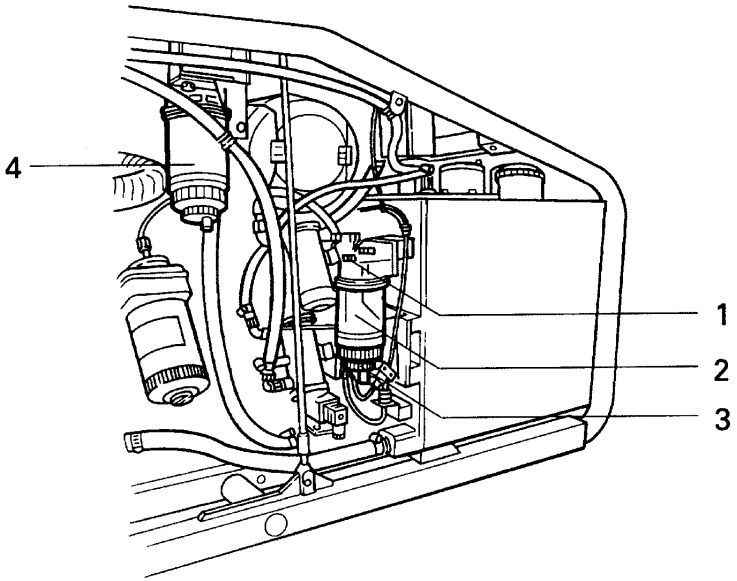

- | | | | |
|---|-----------------|---|-------------|
| 1 | Vent Screw | 3 | Drain Plug |
| 2 | Water Separator | 4 | Fuel Filter |

Figure 10-5: Fuel Filter and Water Separator

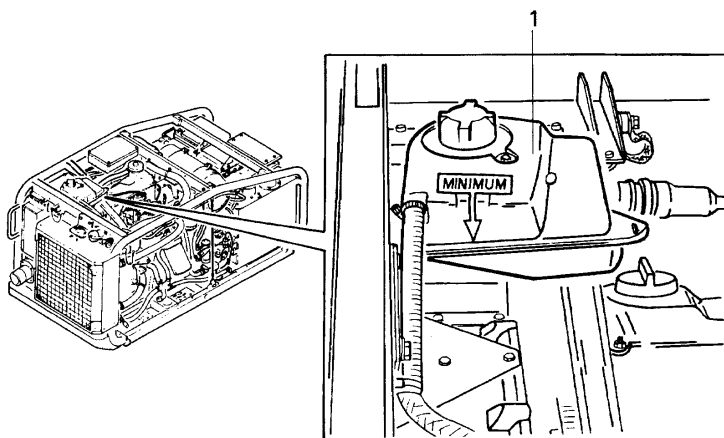

1 Receptacle

Figure 10-6: Coolant Receptacle and Level Mark

CHECK RADIATOR

20. Check exterior of radiator for contamination and leakage. Clean radiator exterior with water jet or compressed air.

SECTION 7 FAULTFINDING/TROUBLESHOOTING

21. The first indication of trouble is usually that one of the following control panel lamps turns on:

- a. TROUBLE SUPPLY.
- b. WARNING.
- c. SAFETY.
- d. TROUBLE VENTILATION.
- e. SUBSYSTEM OFF.

- f. TROUBLE COMPUTER.
- g. TROUBLE SUBSYSTEM.

NOTE

If several of the above lamps are on at the same time, troubleshooting must be performed in the order listed above. When the PSU is operating, but no FCU functions are operational, perform the power distribution Functional Check (start with step 86 005, found at C-79-173-000/MC-001, Part 29).

LAMP TROUBLE SUPPLY

- 22. The lamp TROUBLE SUPPLY must be off during normal operation.
- 23. Malfunctions which are detected by the power distribution monitoring circuits are indicated by the lamp TROUBLE SUPPLY.
- 24. The following indications are possible:
 - a. The lamp TROUBLE SUPPLY is blinking.
 - b. The lamp TROUBLE SUPPLY is on.

LAMP TROUBLE SUPPLY IS BLINKING

- 25. This condition indicates that the fuel level in the PSU tank has dropped to reserve.
- 26. To refuel the PSU, proceed as follows:
 - a. Connect a full spare fuel can to the PSU using the refuelling device.
 - b. Actuate the hand pump on the refuelling device three times.

- c. Set the switch FUEL/REFUELLING on the front panel of the PSU control box for approximately three seconds to REFUELLING.
27. If the refuelling process does not start, proceed as follows:
- a. Switch off the PSU.
 - b. Perform the PSU Functional Check (start with step 85 100, found at C-79-173-000/MC-001, Part 28).

NOTE

If necessary, the PSU can be refuelled manually. Connect the flexible hose to the spare fuel can, remove the cover from the filler neck on top of the PSU tank and refuel the PSU.

LAMP TROUBLE SUPPLY IS ON

28. This condition indicates that one or more faults have been detected by the power supply monitoring circuits.
29. If the lamp TROUBLE SUPPLY is on, perform the power distribution Functional Check (start with step 86 005, found at C-79-173-000/MC-001, Part 29).

LAMP WARNING IS ON

30. The lamp WARNING must be off during normal operation.
31. The lamp WARNING indicates that one or more subsystems are in critical operating conditions, e.g. over temperature in a specific FCU subsystem.
32. If the lamp WARNING is on during a combat situation, proceed as follows:
- a. Continue with the current operation sequence.

- b. As soon as the tactical situation permits, interrupt the current operation sequence, leave the FCU main switch in position OPERATION and perform the power distribution Functional Check (start with step 86 428, found at C-79-173-000/MC-001, Part 29).
33. If the lamp WARNING is on during an exercise or during training, proceed as follows:
- a. Interrupt the current operating sequence.
 - b. Set the FCU main switch to OPERATION.
 - c. Perform the power distribution Functional Check (start with step 86 428, found at C-79-173-000/MC-001, Part 29).

LAMP SAFETY IS ON

34. The lamp SAFETY must be off during normal operation.
35. The lamp SAFETY indicates that one or more of the safety circuits are not reporting normal operational conditions.
36. Verify that the following prerequisites are met:
- a. Locking lever for tilt axis in position OPERATION.
 - b. Locking lever for azimuth axis in position OPERATION.
 - c. Locking lever for elevation axis in position OPERATION.
 - d. Locking lever for search antenna in position OPERATION.
 - e. Switch OPERATION/MAN ON ROOF in position OPERATION.

Skyguard Drill Book

- f. Roof closed and locked.
- g. Bench in operator's cabin in operating position.
- h. Hinged table on the operator console in operating position.

37. If all the above listed prerequisites are met but the lamp SAFETY is still on, perform the power distribution Functional Check (start with step 86 005, found at C-79-173-000/MC-001, Part 29).

LAMP TROUBLE VENTILATION IS ON

38. The lamp TROUBLE VENTILATION must be off during normal operation.

39. The lamp TROUBLE VENTILATION indicates a fault within the ventilation power supply or insufficient airflow in the ventilation system.

40. If the lamp TROUBLE VENTILATION is on, perform the ventilation system Functional Check (start with step 26 000, found at C-79-173-000/MC-001, Part 12).

LAMP SUBSYSTEM OFF IS ON

41. The lamp SUBSYSTEM OFF must be off during normal operation.

42. The lamp SUBSYSTEM OFF indicates that one or more subsystems or functions of the Skyguard are switched off because corresponding service switches on the main distributor are set to OFF.

43. If all service switches on the main distributor are set to ON but the lamp SUBSYSTEM OFF is still on, perform the power distribution Functional Check (start with step 86 005, found at C-79-173-000/ MC-001, Part 29)

LAMP TROUBLE COMPUTER IS ON

44. The lamp TROUBLE COMPUTER must be off during normal operation.
45. The lamp TROUBLE COMPUTER indicates that a failure has occurred in the vital environment of the computer.
46. If the lamp TROUBLE COMPUTER is on, perform the data processing group Functional Check (start with step 72 100, found at C-79-173-000/MC-001, Part 24).

LAMP TROUBLE SUBSYSTEM

47. The lamp TROUBLE SUBSYSTEM must be off during normal operation.
48. The lamp TROUBLE SUBSYSTEM indicates faults which are detected during Operational Monitoring (OPM) during the performance of the Operational Readiness Check (ORC) or during the performance of a Built In Test (BIT)-supported Functional Check (FLC).
49. The following indications are possible:
 - a. The lamp TROUBLE SUBSYSTEM is blinking.
 - b. The lamp TROUBLE SUBSYSTEM is on.

LAMP TROUBLE SUBSYSTEM IS BLINKING

50. Read the message displayed on Field 2 of the system information line on the Plasma Display Monitor (PDM). One of the following messages will be displayed:

MESSAGE	MEANING
FAILURE	Failure of a main function.
PARTIAL FAILURE	Failure of a sub-function or disturbance of a main function. FCU operational capability is degraded.
DISTURBANCE	Disturbance of a sub-function. The main functions remain operable.
WARNING	Functions are not available due to missing input data, which must be entered by the operator; e.g. the Identification Friend or Foe (IFF) Selective Identification Feature (SIF) code is not defined.
MESSAGE ONLY	Operating error, e.g. the operator has depressed a pushbutton on the keyboard, which is disabled in the current operation mode.

51. Press the blinking pushbutton TROUBLE SUBSYSTEM once to confirm the alarm message.

52. If the indication of the lamp TROUBLE SUBSYSTEM changes from blinking to continuously on, proceed with Part 10.7.7.2. If the lamp TROUBLE SUBSYSTEM remains blinking, repeat the procedure as described above (read, assess and confirm the alarm messages) until the lamp TROUBLE SUBSYSTEM is continuously on. Then proceed with Part 10.7.7.2.

NOTE

If the lamp TROUBLE SUBSYSTEM remains blinking after an alarm message is confirmed, two or more faults have been detected. The next alarm message is always displayed after the blinking pushbutton TROUBLE SUBSYSTEM has been depressed. The previous alarm message is stored in the alarm history list.

LAMP TROUBLE SUBSYSTEM IS ON

53. The lamp TROUBLE SUBSYSTEM is on after all alarm messages have been confirmed by the operator and stored in the alarm history list. The next operational sequence depends on the operation performed or in process when the lamp TROUBLE SUBSYSTEM starts blinking:

- a. During normal operation, proceed with Part 10.7.7.3.
- b. During the ORC or a BIT-supported Function Check, proceed with Part 10.7.7.4.

LAMP TROUBLE SUBSYSTEM IS ON DURING NORMAL OPERATION

54. During normal operation, the lamp TROUBLE SUBSYSTEM is controlled via OPM. Depending on the alarm message shown in Field 2 of the PDM information line, proceed as follows:

MESSAGE	ACTION
FAILURE	<p>Interrupt the current operation sequence and depress the pushbutton MENU on the keyboard to select the MK II Main Menu.</p> <p>Select Menu 3/1—BIT/ORC COMPLETE, to start the ORC and follow the instructions given on the PDM.</p>

MESSAGE	ACTION
<p>PARTIAL FAILURE or DISTURBANCE</p>	<p>During a combat situation, continue with the current operation sequence.</p> <p>As soon as the tactical situation permits, interrupt the current operation sequence and depress the pushbutton MENU on the keyboard to select the MK II Main Menu.</p> <p>Select Menu 3/1—BIT/ORC COMPLETE to start the ORC and follow the instructions on the PDM.</p> <p>During an exercise or during training, interrupt the current operation sequence and depress the pushbutton MENU on the keyboard to select the MK II Main Menu.</p> <p>Select Menu 3/1—BIT/ORC COMPLETE to start the ORC and follow the instructions on the PDM.</p>
<p>WARNING or MESSAGE ONLY</p>	<p>Perform the required actions according to the information shown on Field 3 of the PDM system information line.</p>

LAMP TROUBLE SUBSYSTEM IS ON DURING BIT

55. The lamp TROUBLE SUBSYSTEM is on during the performance of the ORC or while a BIT-supported Functional Check is being run. Follow the instructions on the PDM.

LAMP TROUBLE AT THE PSU IS ON

56. The lamp TROUBLE at the PSU must be off during normal operation.

57. The lamp TROUBLE at the PSU indicates that one or more faults have been detected by the PSU monitoring circuits. Set the

switch ERROR/DISPLAY TEST on the control box briefly to ERROR and read the error code on the display.

58. If any error code except 04 or 08 appears on the display, perform the PSU Functional Check (start with step 85 525 found at C-79-173-000/MC-001, Part 28).
59. If error code 04 appears on the display, let the PSU run in STAND BY mode for at least 10 minutes. If the lamp TROUBLE is still on after 10 minutes, perform the PSU Functional Check (start with step 85 525 found at C-79-173-000/MC-001, Part 28).
60. If error code 08 appears on the display, switch the PSU off and check the power connection between the PSU and the FCU. If the power connection between the PSU and the FCU is correct and the lamp TROUBLE is still on after the PSU is restarted, perform the PSU Functional Check (start with step 85 525 found at C-79-173-000/MC-001, Part 28).

LAMP PUMP ON REMAINS OFF AFTER HYDRAULIC PUMP IS STARTED

61. The lamp PUMP ON must turn on approximately five seconds after the hydraulic pump is started.
62. If the lamp PUMP ON does not switch on five seconds after the hydraulic pump is started or if the hydraulic pump does not start, set the FCU main switch to STAND BY. Perform the hydraulic group Functional Check (start with step 82 200 found at C-79-173-000/MC-001, Part 27).

LAMP SAFETY ROOF IS OFF

63. The lamp SAFETY ROOF must be on when all conditions have been met to open or close the roof by depressing the corresponding pushbutton on the switch-on panel.
64. The following prerequisites must be met before the lamp SAFETY ROOF can turn on:

- a. FCU main switch is set to:
 - (1) OFF and the hydraulic pump is switched on,
 - (2) STAND BY, or
 - (3) OPERATION.
- b. Switch OPERATION/MAN ON ROOF is set to OPERATION.
- c. Tracker is completely tilted down or is completely tilted up, and the tilt axis locking lever is set to OPERATION.
- d. Both covers of the electronics cabinet are closed.
- e. Locking lever for the tracker azimuth axis is set to TRANSPORT.

65. If all the above listed conditions have been met but the lamp is still off, set the FCU main switch to STAND BY. Perform the hydraulic group Functional Check (start with step 82 400 found at C-79-173-000/MC-001, Part 27).

SECTION 8 CORRECTIVE MAINTENANCE

66. Corrective maintenance tasks will be performed on the following assemblies:

- a. Operator Console.
- b. Vehicle Lighting.
- c. PSU.
- d. Switch-On Panel.
- e. Cabin Light.

INSTRUCTIONS FOR REPAIR WORK

67. Unless otherwise specified, face in the direction of travel when locating right and left hand positions of assemblies.
68. Before starting repair work, set the FCU main switch to OFF and disconnect the FCU from the power source.
69. After completing a maintenance task, verify proper functioning.

ADJUSTMENTS

70. Adjustments are not performed at operator level.

REMOVE/REPLACE LAMPS AT THE OPERATOR CONSOLE (SEE FIGURE 10-7)

71. To remove or replace lamps at the operator console:
 - a. Use the cap extractor (2) to remove the cap (1) with the lamp.
 - b. Replace the defective lamp (3).
 - c. Install cap.

REMOVE/REPLACE VEHICLE LIGHTING LAMP

72. To remove or replace vehicle lighting lamp:
 - a. Remove the cover and lens from the light fixture with the defective lamp.
 - b. Replace the defective lamp.
 - c. Install the cover with lens.

REMOVE/REPLACE BATTERIES ON THE PSU (SEE FIGURE 10-8)

- 73. To remove or replace batteries on the PSU:
 - a. Loosen and remove battery cable connectors (1).
 - b. Loosen the four captive screws (3) and take off both straps (4).
 - c. Remove batteries (2).
 - d. Replace batteries.
 - e. Install parts in reverse order.

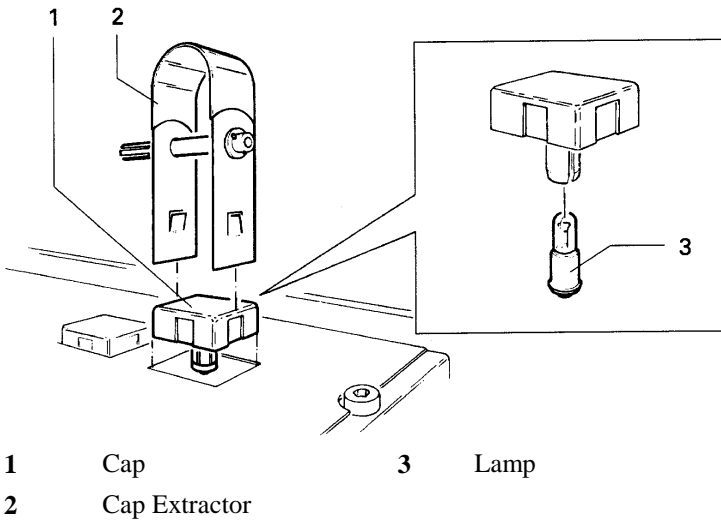
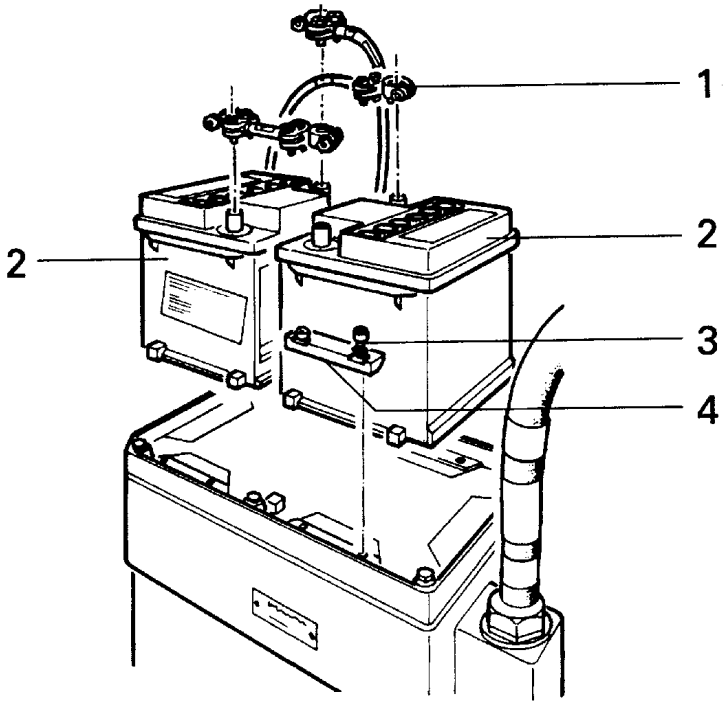

Figure 10-7: Remove/Replace Lamps at the Operator Console



- | | | | |
|---|-----------|---|---------------|
| 1 | Connector | 3 | Captive Screw |
| 2 | Battery | 4 | Strap |

Figure 10-8: Remove/Replace Batteries

TOP UP BATTERY ELECTROLYTE LEVEL

74. Top up acid level to approximately 5 mm above the plates.

CAUTION

1. Only chemically pure, distilled water must be used to top up the batteries.
2. Battery fluid is highly corrosive. Do not lay metal objects on the batteries.
3. Keep naked flames well away from batteries.
4. Smoking is forbidden in the vicinity of the batteries.

**REMOVE/REPLACE LAMPS ON THE SWITCH-ON PANEL
(SEE FIGURE 10-9)**

75. To remove or replace lamps on the switch-on panel:
- a. Remove the lens (1) with the special wrench (2).
 - b. Use the lamp extractor (4) to replace the defective lamp (3).
 - c. Install the lens.

REMOVE/REPLACE CABIN LIGHTING LAMPS

76. To remove or replace cabin lighting lamps:
- a. Open the cover by unfastening the hinged snap closure.
 - b. Replace the defective lamp.
 - c. Close the cover by fastening the hinged snap closure.

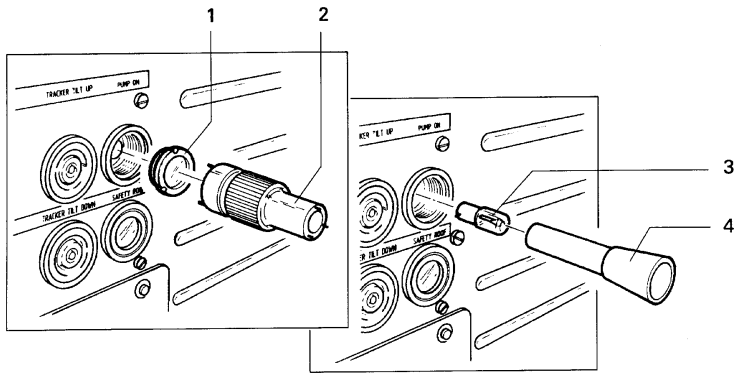

- | | | | |
|---|----------------|---|----------------|
| 1 | Lens | 3 | Lamp |
| 2 | Special Wrench | 4 | Lamp Extractor |

Figure 10-9: Remove/Replace Lamps on the Switch-On Panel

REMOVE/REPLACE WHEEL (SEE FIGURE 10-10)

77. To remove:

- a. Loosen six plain nuts (4) approximately $\frac{1}{2}$ to 1 turn.
- b. Using hydraulic group, raise FCU until wheel (1) to be removed is about 5 cm above the ground.
- c. Remove plain nuts (4) and clamping plates (3).
- d. Remove wheel (1) from capstan wheel (2). (**NOTE:** The wheel has a weight of 75 kg.)

78. To replace:

- a. Clean all parts and check for wear before installing.
- b. Place wheel on capstan wheel so that the valve and the two stops of the rim lie between two spokes of the capstan wheel.
- c. Install clamping plates and plain nuts.

- d. Gradually tighten plain nuts one after the other (not crosswise) a half turn at a time and repeat procedure several times. (**NOTE:** To keep wheel from turning, set hand brake or lower FCU until the wheel barely touches the ground.)
- e. Check tires pressure and correct if necessary.
- f. Retighten the plain nuts after the FCU has been towed a short distance.

WARNING

Tighten the plain nuts to the required torque of 350 Nm as soon as possible. Retighten the plain nuts again after approximately 100 km.

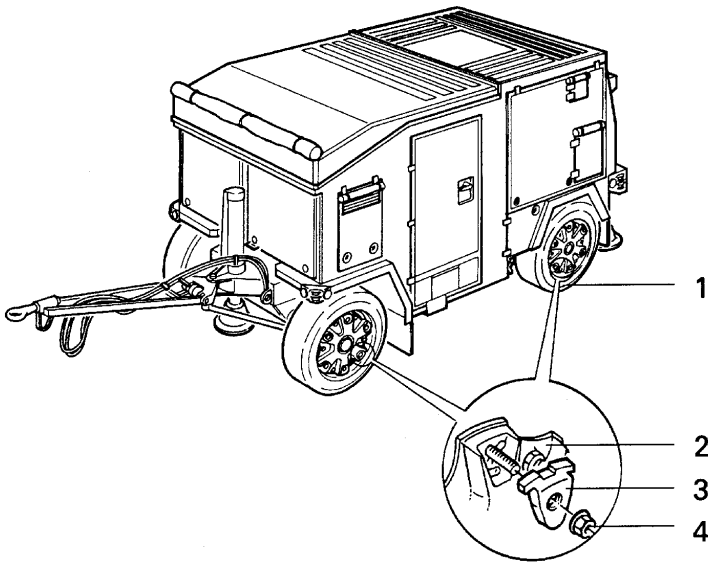

- | | | | |
|---|---------------|---|----------------|
| 1 | Wheel | 3 | Clamping Plate |
| 2 | Capstan Wheel | 4 | Plain Nut |

Figure 10-10: Remove/Replace Wheel

LIST OF ABBREVIATIONS

A/BCP	Alternate Battery Command Post
ASM	Air-to-Surface Missile
BCP	Battery Command Post
BIT	Built In Test
CIS	Communication and Intercom System
DDS	Digital Data Set
DMD	Distance Measuring Device
DPG	Data Processing Group
DSA	Dual Suppression Algorithm
ECCM	Electronic Counter Countermeasures
ECM	Electronic Countermeasures
EOG	Electro-Optical Group
FCSS	Fire Control and Select System

Skyguard Drill Book

FCU	Fire Control Unit
FID	Failure Identification
FLC	Functional Check
FP	Firing Point
FPO	Firing Point Officer
GEN	Generator
IFF	Identification Friend or Foe
LED	Light-emitting Diode
LSS	Laser Safety Supervisor
MTI	Moving Target Indication
MV	Muzzle Velocity
NTDR	Near Term Digital Radio
OIC	Officer in Charge
OPM	Operational Monitoring

List of Abbreviations

ORC	Operational Readiness Check
OS	Optical Sight
PDM	Plasma Display Monitor
PMS	Preventive Maintenance Schedule
PPI	Plan Position Indicator
PRF	Pulse Repetition Frequency
PSU	Power Supply Unit
REO	Range Equipment Operator
RSO	Range Safety Officer
SIF	Selective Identification Features
SRDE	Search Radar Data Extractor
STC	Sensitivity Time Control
SUP	Start Up
TC	Troop Commander
TEU	Tracking Error Unit

Skyguard Drill Book

Tfli	Shells Flying Time
TS 2	Training Simulator 2
TSM	Troop Sergeant Major
TV	Television
TVG	Time Variable Gain
TWS	Track While Scan
VDG	Video Display Generator
VES	Video Evaluation System
VT	Video Tracker
WSO	Weapon Safety Officer